



# WUXGA OLED-XL™ Microdisplay

## WUXGA OLED-XL MICRODISPLAY CAPABILITIES

The WUXGA OLED-XL microdisplay from eMagin Corporation is an active-matrix organic light emitting diode (AMOLED) microdisplay intended for near-to-eye applications that demand high resolution, high quality imaging, compact size, and very low power. Combining a total of 7,138,368 active dots, the WUXGA microdisplay is built on a single crystal silicon backplane and features eMagin's proprietary thin-film OLED XL technology offering extended life and luminance performance.

Fully 3D capable, the WUXGA OLED-XL design also features eMagin's proprietary "Deep Black" architecture that ensures off-pixels are truly black, automatically optimizes contrast under all conditions, and delivers imagery that is hard to separate from reality. The WUXGA microdisplay includes circuitry that ensures a full 256 gamma-corrected gray levels; an on-chip set of look-up-tables for digital gamma correction; and pulse-width-modulation (PWM), which together with the standard analog control, provides an extended dimming range. The PWM function also enables an impulse drive mode of operation that significantly reduces motion artifacts in high-speed scene changes.

The active array is comprised of 1944 x 1224 square pixels with a 9.6-micron pitch and a 71% fill factor. An extra 24 columns and 24 rows (beyond the 1920 x 1200 main array) are provided to enable the active window of the WUXGA microdisplay to be shifted by up to 12 pixels, horizontally and vertically for optical alignment purposes. Each full pixel is laid out as three 3.2 x 9.6 micron identical sub-pixels, which together form the 9.6-micron square RGB color group. Three primary color filter stripes are applied in alignment with the sub-pixels on a white-emissive OLED layer to form the color display.

The WUXGA OLED-XL microdisplay includes a very low-power, low-voltage-differential-signaling (LVDS) serialized interface for video data transport that minimizes the number of board interconnections and connector size; reduces electromagnetic emissions (EMI) and enables a lightweight and flexible cable link to a remote video source. Compatibility with standard LVDS drivers simplifies system integration.



## WUXGA OLED-XL MICRODISPLAY ADVANTAGES

- Compact, lightweight, HD emissive display
- Ultra High-resolution/very low power
- Deep Black™ high contrast (up to 100,000:1)
- Instant on at low temperatures/no heaters
- Integrated temperature sensor
- Low power LVDS interface
- High commercial/military ruggedness
- No back light or liquid materials required

## APPLICATIONS

- Immersive 3D HD Gaming/Video Headsets
- Augmented reality HMDs
- HD Resolution Electronic Viewfinders
- Computer-based 3D Simulation & Training
- Night vision/thermal imaging devices
- Medical/Scientific imaging
- Fixed and Rotary Wing aircraft HMDs

### eMagin Corporation

700 South Drive Suite #201  
Hopewell Junction, NY 12533  
tel 845.838.7900  
fax 845.838.7901  
[www.emagin.com](http://www.emagin.com)

## GENERAL OPERATING CHARACTERISTIC

### FORM A T

- 1920 (x 3) x 1200
- Total pixel array 1944 (x3) x 1244

### PIXEL PITCH & ASPECT RATIO

- 9.6  $\mu$  square

### COLOR PIXEL ARRANGEMENT

- R,G,B vertical stripe

### VIEWING AREA

- 18.7 x 11.75 mm (22.1 mm diagonal (0.856"))
- Electronic image centering (1 to 12 pixels H and V)

### DISPLAY ASPECT RATIO

- Wide Format

### MECHANICAL ENVELOPE

- 26.4 x 17.5 x 4.72 mm (L x W x H)

### COLOR GAMUT

- >75% of NTSC gamut
- Up to 256 gray levels

### UNIFORMITY

- >85% End to end
- >95% Pixel to pixel uniformity

### CONTRAST RATIO

- >10,000:1
- Dimming ratio >500:1 with CR> 1,000:1 Typical

### LUMINANCE

- 400 cd/m<sup>2</sup> (white luminance – full color display)

### TEMPERATURE

- Operating: -45°C to >+65°C
- Storage: -55°C to +90°C

### H UMIDITY

- 85% RH non-condensing

### VIDEO INPUTS

#### R, G, B INPUTS

- Serialized LVDS, 24b Digital RGB (8 twisted line pairs)

#### VIDEO FORMATS

- WUXGA, 1080p, UXGA
- Frame or Field sequential stereovision

#### VIDEO SIGNAL BANDWIDTH

- 220 MHz maximum

#### CONTROL & SERIAL INTERFACE

- I<sup>2</sup>C Serial Interface

#### FRAME RATE

- 30 to 85 Hz

### POWER INTERFACE

#### POWER SUPPLY (V<sub>DD</sub>)

- 1.8 Vdc (logic), 5Vdc analog/display

#### TOTAL POWER DISSIPATION

- <350 mW typical @ 150cd/m<sup>2</sup>
- 1W peak (25°C, 60 Hz, all pixels on)

\* Data represent performance at 20°C for standard commercial and industrial pricing. Characteristics will vary with temperature requirements. Low-cost commercial or consumer operating specifications may vary.

All specifications are subject to change.

## LVDS INTERFACE DIAGRAM

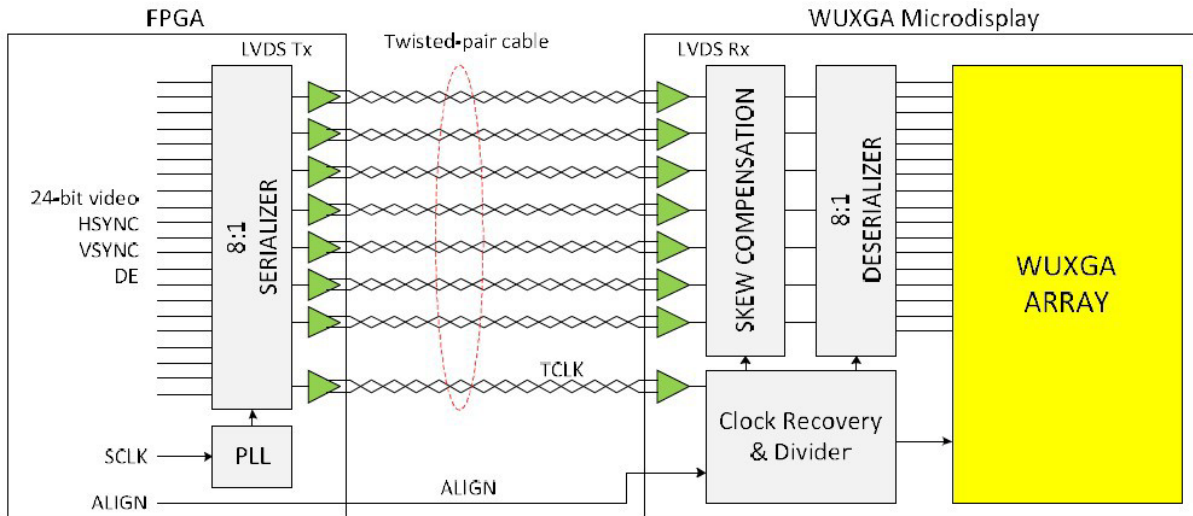

eMagin Corporation is a registered trademark of eMagin Corporation. All other products mentioned herein are trademarks of their respective owners and are hereby recognized as such. eMagin Corporation reserves the right to change products and specifications without prior notice. This information does not convey any license by any implication or otherwise under any patents or other rights. Application circuits shown, if any, are typical examples illustrating the operation of the devices. This information is subject to change without notice. ©2023, eMagin Corporation, Hopwell Junction, NY. All rights reserved.