

SXGA-096 MGXLT

**1280 X 1024 LOW-POWER MONOCHROME GREEN XLT
AMOLED MICRODISPLAY WITH FLAT FIBEROPTIC
FACEPLATE**



DATASHEET
Revision C

For Part Numbers:

EMA-101210-05

eMagin Corporation reserves the right to change products and specifications without prior notice. This information does not convey any license by any implication or otherwise under any patents or other rights. Application circuits shown, if any, are typical examples illustrating the operation of the devices. eMagin Corporation cannot assume responsibility for any problem arising out of the use of these circuits

Revision Level	ECN	Date	Scope
-		May-2016	Initial Release
A	000522	Jul - 2018	Updated 9.4.5, Updated eeprom map (p98)
B	000877	Dec-2019	Updated assembly views (Fig 17 & 18) to comply with geometric tolerancing standard
C	001210	01-21-2022	Connector change pp 10, 25

TABLE OF CONTENTS

1. INTRODUCTION	5
2. GENERAL DESCRIPTION.....	6
2.1 SXGA-096 MONOCHROME GREEN XLT MICRODISPLAY	6
3. FUNCTIONAL OVERVIEW.....	7
3.1 LVDS PORT MAPPING	9
4. INPUT / OUTPUT DESCRIPTION	10
4.1 MINIMUM CONFIGURATION	10
4.2 TYPICAL CONFIGURATION	11
5. PIXEL ARRAY LAYOUT.....	12
6. ELECTRICAL CHARACTERISTICS	13
6.1 TIMING CHARACTERISTICS	17
6.1.1 Video Input Timing Diagrams	17
6.1.2 Gamma Sensor Timing Diagram	19
7. OPTICAL CHARACTERISTICS	20
7.1 ROOM TEMPERATURE CHARACTERISTICS	20
7.2 CHARACTERISTICS OVER FULL OPERATIONAL TEMPERATURE RANGE (-46°C TO +71°C)	23
8. MECHANICAL CHARACTERISTICS	25
9. DETAILED FUNCTIONAL DESCRIPTION	29
9.1 VIDEO INTERFACE.....	29
9.2 D/A CONVERSION	32
9.3 FORMAT AND TIMING CONTROL	33
9.3.1 Vertical Position Control.....	33
9.3.2 Horizontal Position Control	34
9.3.3 Interlaced Modes	34
9.3.4 Stereovision Mode	34
9.3.5 Row Duty Rate Control.....	35
9.4 SENSOR FUNCTIONS	37
9.4.1 Temperature Readout	37
9.4.2 Luminance Regulation Sensor	37
9.4.3 Pixel Bias Sensor	37
9.4.4 Luminance Control (Dimming).....	37
9.4.5 Luminance Setting	38
9.4.6 Gamma Correction Sensor	39
9.5 DC-DC CONVERTER	45
9.6 SERIAL INTERFACE.....	47
9.7 POWER-ON SEQUENCE.....	49
9.8 POWER SAVINGS MODES.....	50
9.9 BUILT-IN TEST PATTERNS.....	50
10. REGISTER MAP SUMMARY	52
11. DETAILED REGISTER DESCRIPTIONS.....	55
11.1 STAT (00H)	55
11.2 VINMODE (01H)	55
11.3 DISPMODE (02H).....	57
11.4 LFTPOS (03H).....	58
11.5 RGTPOS (04H).....	59

11.6	TOPPOS (05H)	59
11.7	BOTPOS (06H)	59
11.8	ROWRESET (07H, 08H)	60
11.9	RAMPCTL (09H)	60
11.10	RAMPCM (0AH)	61
11.11	VDACMX (0BH)	62
11.12	BIASN (0CH)	64
11.13	GAMMASET (0DH)	64
11.14	VCOMMODE (0EH)	65
11.15	VCOMCTL (0FH)	66
11.16	VGMAX (10H)	67
11.17	VCOM (11H)	67
11.18	IDRF (12H)	68
11.19	DIMCTL (13H)	69
11.20	TREFDIV (14H)	69
11.21	TEMPOFF (15H)	70
11.22	TUPDATE (16H)	70
11.23	TEMPOUT (17H)	71
11.24	ANGPWRDN (18H)	73
11.25	SYSPWRDN (19H)	74
11.26	TPMODE (1AH)	75
11.27	TPLINWTH (1BH)	77
11.28	TPCOLSP (1CH)	78
11.29	TPROWSP (1DH)	78
11.30	TPMONOCHROME WHITE (1EH)	78
11.31	DLYSEL (1FH)	79
11.32	LVDSCTL (20H)	80
11.33	SKEW0 (21H, 22H)	81
11.34	SKEW1 (23H, 24H)	82
11.35	SKEW2 (25H, 26H)	82
11.36	SKEW3 (27H, 28H)	83
11.37	SKFAST (29H)	83
11.38	SKSLOW (2AH)	84
11.39	SYNCMOD (2BH)	84
11.40	LUT_ADDR (2CH)	84
11.41	LUT_DATA (2DH, 2EH)	85
11.42	LUT_UPDATE (2FH)	85
11.43	RESERVED (30H, 31H, 32H, 33H)	87
11.44	RESERVED (34H, 35H)	87
11.45	RESERVED (36H)	87
11.46	RESERVED (37H)	87
11.47	RESERVED (38H, 39H)	88
11.48	RESERVED (3AH)	88
11.49	RESERVED (3BH)	88
11.50	RESERVED (3CH)	88
11.51	RESERVED (3DH)	89
11.52	RESERVED (40H)	89
11.53	RESERVED (41H)	89
11.54	RESERVED (42H)	89
12.	APPENDIX A: APPLICATION SYSTEM DIAGRAM	90
13.	APPENDIX B: LVDS TX DESIGN EXAMPLE	91
14.	APPENDIX C: EEPROM MEMORY MAP	97
15.	APPENDIX D: RECOMMENDED REGISTER SETTINGS	100

1. INTRODUCTION

The SXGA-096 Monochrome Green OLED-XLT with 0.7mm flat FOP (SX096 MGXLTFP) device from eMagin Corporation is an active-matrix organic light emitting diode (AMOLED) microdisplay intended for near-to-eye applications that demand high brightness, high resolution, high image quality, compact size, and low power. Combining a total of 4,015,536 active dots, the SXGA-096 display is built on a single crystal silicon backplane and features eMagin's proprietary thin-film Green OLED XLT technology offering extended life and luminance performance. The array is covered by a flat fiber-optic faceplate featuring 3-micron hexagonal-shaped fibers, which results in an image plane coincident with the top surface of the microdisplay assembly.

The active array is comprised of 1292 x 1036 square pixels with a 9.6-micron pitch and a 75% fill factor. An extra 12 columns and 12 rows (beyond the 1292 x 1036 main array) are provided to enable the active SXGA-096 display to be shifted by steps of 1 pixel in the X and Y directions for optical alignment purposes. Additional dummy and test pixels surround the active array. Each full pixel is laid out as three 3.2 x 9.6 micron identical sub-pixels, which together form the 9.6-micron square pixel. The three sub-pixels provide built-in redundancy from a defect standpoint

The SXGA-096 monochrome green microdisplay can be configured to be driven by a single 8-bit data interface, reducing the interconnect requirements at system level. The microdisplay connector still provides three 8-bit ports should the user prefer to control each sub-pixel independently.

The SXGA-096 design features eMagin's proprietary "Deep Black" architecture that ensures off-pixels are truly black, automatically optimizes contrast under all conditions, and delivers improved pixel uniformity. In addition to its flexible matrix addressing circuitry, the SXGA-096 includes an internal 10-bit DAC that ensures 256 fully gamma-corrected gray levels, an on-chip set of look-up-tables for digital gamma correction, and a novel pulse-width-modulation (PWM) function that, together with the standard analog control, provides an extended dimming range. The PWM function also enables an impulse drive mode of operation that significantly reduces motion artifacts in high speed scene changes.

The SXGA-096 includes a very low-power, low-voltage-differential-signaling (LVDS) serialized interface for video data transport that minimizes the number of board interconnections and connector size, reduces electromagnetic emissions (EMI), and enables a lightweight and flexible cable link to a remote video source. Compatibility with standard LVDS drivers found in most commercially available FPGAs simplifies the system integrators task.

Detailed device specifications and application information for the SXGA-096 OLED-XLT microdisplay produced by eMagin Corporation are provided in this document.

2. GENERAL DESCRIPTION

2.1 SXGA-096 Monochrome Green XLT Microdisplay

Parameter	Specification ¹
Display Type	Emissive, Monochrome Green Active Matrix Organic Light Emitting Diode on Silicon
Format	1280 (x3) x 1024 pixels
Total Pixel Array	1292 (x3) x 1036 pixels
Color Pixel Aspect Ratio	9.6 micron square pixel
Sub Pixel Arrangement	Vertical Stripe, 3 sub-pixel
Display Area	12.4 x 9.945 mm (15.9 mm diagonal (0.62"))
Useable Display Area	20.0 x 16.5 x 5.0 mm (w x l x h)
Mechanical Envelope	18.0 x 16.0 x 5.01 mm (rigid carrier board)
Weight	~ 3 grams
Gray Levels	256
Uniformity	> 85% end to end
Contrast Ratio	> 10,000:1 typical
Dimming Ratio	>400:1 with CR> 1,000:1 typical
Green Luminance	≥ 5,000 cd/m ² (front luminance), SXGA 60Hz VESA mode
Video Interface	Serialized LVDS, 8/24 Digital (up to 5 twisted line pairs including the clock pair)
Video Source Clock	120 MHz maximum (VESA mode), up to 85 Hz frame rate
Control & Serial Interface	Digital 1.8V CMOS
Power Interface	
IO/Front-end Supply (VDD1.8)	1.8 Volts DC @ 10 mA maximum
Array/Analog Supply ² (VDD5)	5.0 Volts DC @ 50 mA maximum
Bias Supply (VPG)	-1.5 Volts DC @ 1 nA maximum
Operating Ambient Temperature	-45°C to +70°C
Storage Temperature	-55°C to +90°C
Humidity	85%RH non-condensing

Note 1: The above data represents typical performance specifications measured at 20°C ambient temperature.

Note 2: Includes internally generated negative cathode supply.

3. FUNCTIONAL OVERVIEW

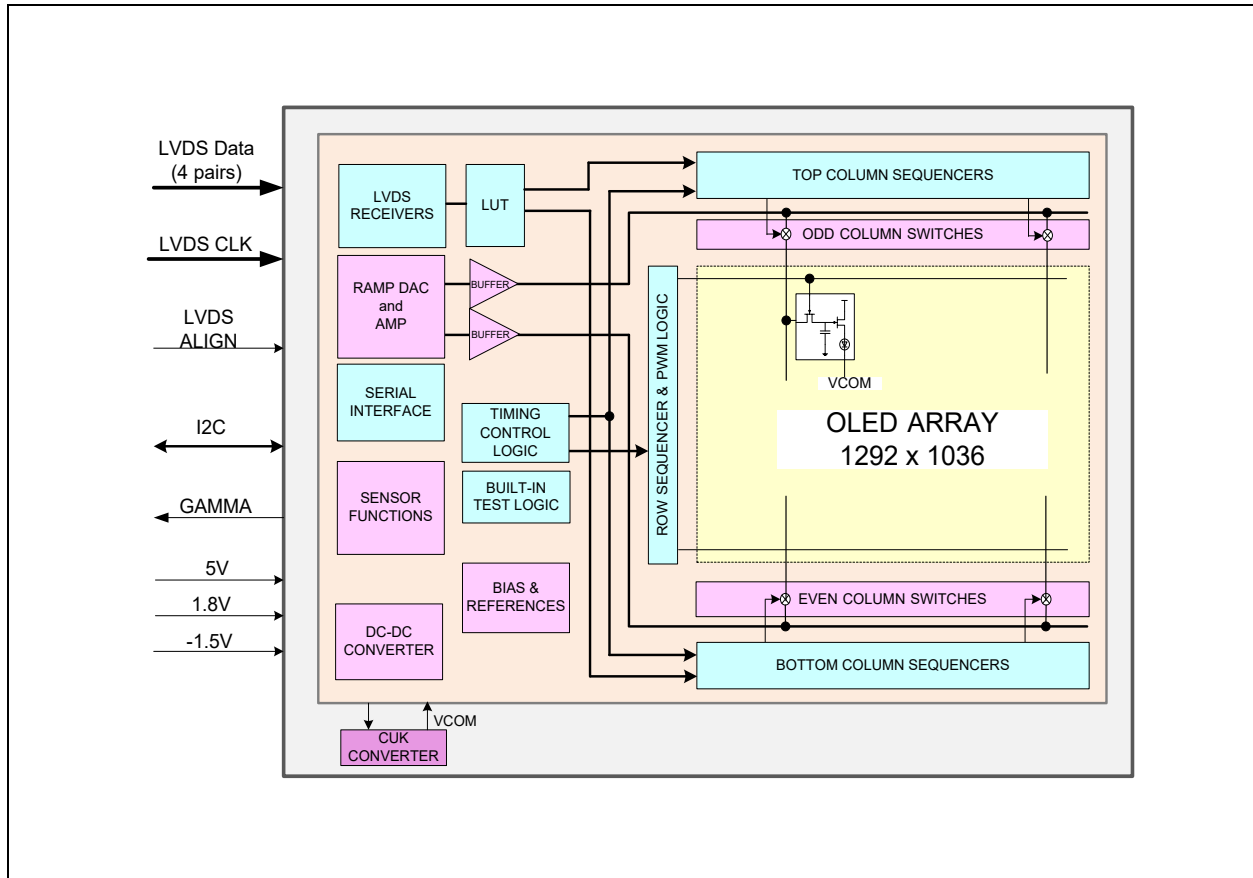

Figure 1: Top-level block diagram for SXGA-096

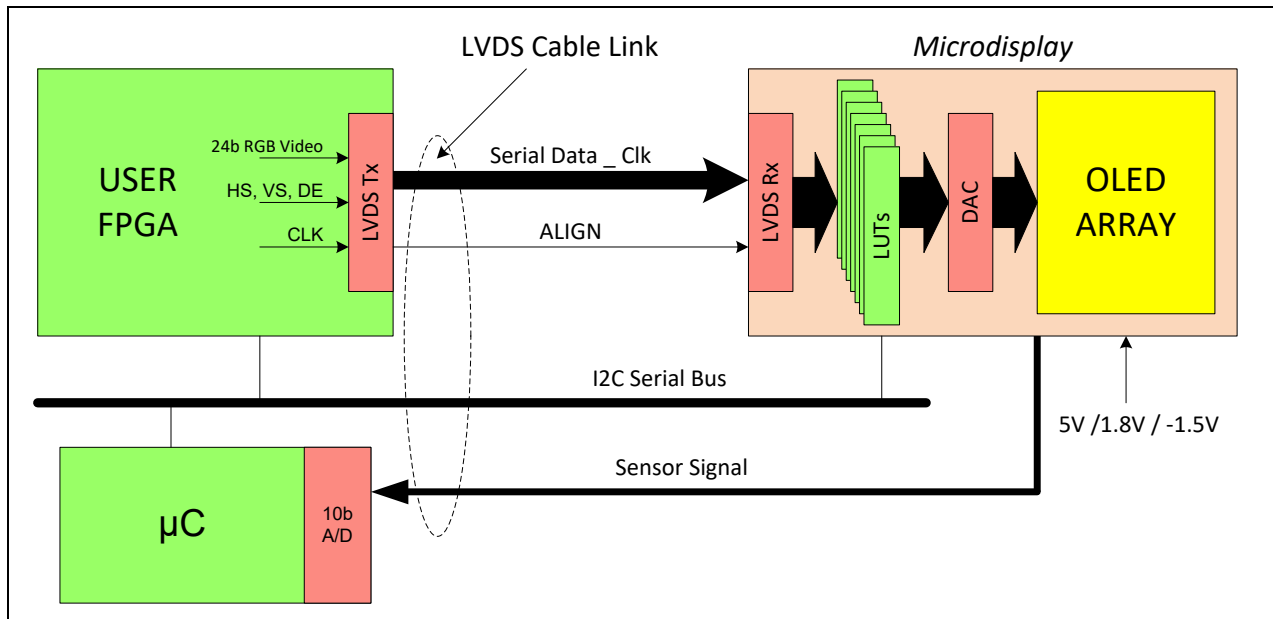

Figure 2: System application diagram

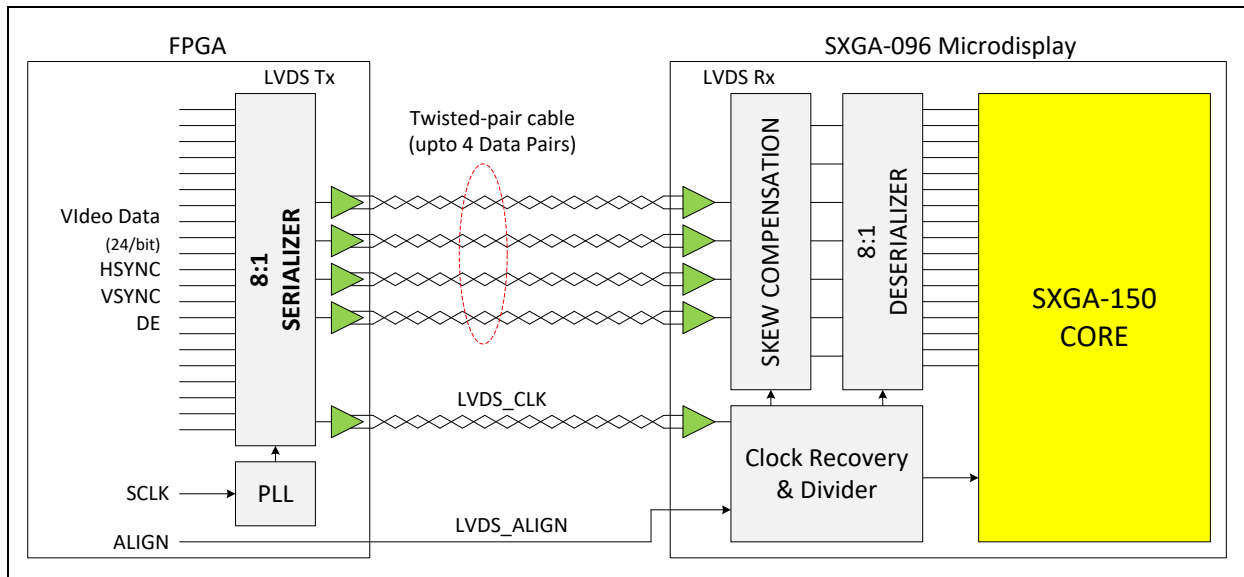

Figure 3: LVDS interface diagram

3.1 LVDS Port Mapping

The SXGA-096 microdisplay backplane (Silicon CMOS integrated Circuit) is designed to support full color operation (RGB) and the data interface can accept up to 24 bits.

For monochrome only application, such as the SXGA096 Monochrome Green XLT microdisplay, it is possible to reduce the number of interconnects by taking advantage of the built-in monochrome mode, which can be set in the DISPMODE register (Register 02, Bit 6). In this mode, (Bit 6 = 1), only one 8-bit data port is required and internal circuitry replicates the 8-bit value to the 3 sub-pixels that make up the full pixel.

This eliminates the need for 2 of the 4 LVDS pairs used to connect the SXGA096 microdisplay to the host interface. Pairs RD0 and RD3 can be left unconnected.

Figure 4 below shows the correspondence between the LVDS pairs and the data/control signals they carry.

Bits	RD0	RD1	RD2	RD3
7	R7	G6	R0	B5
6	R1	G5	DE	B4
5	R6	G1	HSYNC	B3
4	R5	G0	ENABLE	B1
3	R4	G4	VSYNC	B0
2	R3	G3	B7	B2
1	R2	G2	G7	B6
0	Dummy	Dummy	Dummy	Dummy

Figure 4: LVDS – Data/Control Mapping

4. INPUT / OUTPUT DESCRIPTION

Connector J1 is a Hirose DF12NB(3.0)-30DP-0.5V(51) or DF12D (3.0)-30DP-0.5V (obsolete as of 12-31-2021)

4.1 Minimum Configuration

Connector J1

Pin #	Pin Name	Type	Description
1	GND	Power	Power return terminal.
2	VPG	Power	Negative voltage bias for array protection switch. (-1.4 V)
3	RD3P	Open	Not used. Leave open
4	GND	Power	Power return terminal.
5	RD3N	Open	LVDS Digital Data and Sync Input Port.
6	VDD5	Power	Input power for Analog Circuits (5VDC).
7	GND	Power	Power return terminal.
8	VDD5	Power	Input power for VCOM (5VDC).
9	RD2N	LVDS	LVDS Digital Data and Sync Input Port.
10	VDD5	Power	Input power for Pixel Array (5VDC).
11	RD2P	LVDS	LVDS Digital Data and Sync Input Port.
12	GND	Power	Power return terminal.
13	GND	Power	Power return terminal.
14	VDD1.8	Power	Input power for logic and I/O pads.
15	RCKN	LVDS	LVDS source clock.
16	VGN	Analog Out	Gamma sensor output signal. (0 to +2.5V)
17	RCKP	LVDS	LVDS source clock.
18	BURN_IN	Logic In	Activates test mode used for Burn-In.
19	GND	Power	Power return terminal
20	RESETB	Logic In	Asynchronous system reset (active low).
21	RD1N	LVDS	LVDS Digital Data Input Port.
22	ENABLE	Logic In	Enable logic input.
23	RD1P	LVDS	LVDS Digital Data Input Port.
24	SCL	Logic In	Clock port for the serial interface. 400 KHz Max.
25	GND	Power	Power return terminal
26	SDA	Logic I/O	Data port for the serial interface. Open collector output
27	RD0N	Open	LVDS Digital Data and Sync Input Port.
28	SERADD	Logic In	Serial interface LSB address bit. Must be connected.
29	RD0P	Open	Not used. Leave open
30	LVDS_ALGN	Logic In	LVDS logic initialization signal (CMOS input).

4.2 Typical Configuration

Connector J1

Pin #	Pin Name	Type	Description
1	GND	Power	Power return terminal.
2	VPG	Power	Negative voltage bias for array protection switch. (-1.4 V)
3	RD3P	LVDS	LVDS Digital Data Input Port.
4	GND	Power	Power return terminal.
5	RD3N	LVDS	LVDS Digital Data Input Port.
6	VDD5	Power	Input power for Analog Circuits (5VDC).
7	GND	Power	Power return terminal.
8	VDD5	Power	Input power for VCOM (5VDC).
9	RD2N	LVDS	LVDS Digital Data and Sync Input Port.
10	VDD5	Power	Input power for Pixel Array (5VDC).
11	RD2P	LVDS	LVDS Digital Data and Sync Input Port.
12	GND	Power	Power return terminal.
13	GND	Power	Power return terminal.
14	VDD1.8	Power	Input power for logic and I/O pads.
15	RCKN	LVDS	LVDS source clock.
16	VGN	Analog Out	Gamma sensor output signal. (0 to +2.5V)
17	RCKP	LVDS	LVDS source clock.
18	BURN IN	Logic In	Activates test mode used for Burn-In.
19	GND	Power	Power return terminal
20	RESETB	Logic In	Asynchronous system reset (active low).
21	RD1N	LVDS	LVDS Digital Data Input Port.
22	ENABLE	Logic In	Enable logic input.
23	RD1P	LVDS	LVDS Digital Data Input Port.
24	SCL	Logic In	Clock port for the serial interface. 400 KHz Max. (5V)
25	GND	Power	Power return terminal
26	SDA	Logic I/O	Data port for the serial interface. Open collector output (5V)
27	RD0N	LVDS	LVDS Digital Data Input Port.
28	SERADD	Logic In	Serial interface LSB address bit. Must be connected.
29	RD0P	LVDS	LVDS Digital Data Input Port.
30	LVDS ALGN	Logic In	LVDS logic initialization signal (CMOS input).

6. ELECTRICAL CHARACTERISTICS

Table 6-1 : Absolute Maximum Ratings

Symbol	Parameter	Min	Typ.	Max.	Unit
VDD1.8	Front End Power Supply	-0.3		2.5	VDC
VDD5	Array/Analog Power Supply	-0.3		5.5	VDC
VCOM	Common electrode bias	-6		0	VDC
VPG	Array Bias Supply	-3		0	VDC
VI	Input Voltage Range	-0.3		VDD+0.3	VDC
VO	Output Voltage Range	-0.3		VDD+0.3	VDC
PD	Power Dissipation			1	W
Tst	Storage Temperature	-55		+90	°C
Tj	Junction Temperature	-45		+125	°C
Ilu	Latch up current			+100	mA
Vesd	Electrostatic Discharge – Human Body Model			±2000	V

Stresses at or above those listed in this table may cause permanent damage to the device. This is a stress rating only and functional operation of the device at these or any other condition above those indicated in the following tables is not implied. Exposure to absolute maximum rated conditions for extended periods may affect device reliability (except for the reverse bias condition. See below). Prolonged exposure to high temperatures will shorten the luminance half-life.

Table 6-2 : Recommended Operating Conditions

Symbol	Parameter	Min	Typ.	Max.	Unit
VDD1.8	Front End Power Supply	1.71	1.8	1.89	VDC
VDD5	Array/Analog Power Supply	4.75	5	5.25	VDC
VCOM	Common electrode bias	-5	-2.0	0	VDC
VPG	Array Bias Supply	-3	-1.4	0	VDC
Tst	Storage Temperature	-55		+90	°C
Ta	Ambient Operating Temp.	-45	+25	+70	°C
Pdt	All Pixels On Power Consumption		300		mW

Table 6-3 : DC Characteristics

(Ta = 25°C, VDD1.8 = +1.8V, VDD5 = +5V, GND = 0V)

Symbol	Parameter	Min	Typ.	Max.	Unit
VDD1.8	Front End Power Supply		1.8		V
VDD5	Array/Analog Power Supply		5		V
VCOM	Common electrode bias	-5	-2.0	0	V
VPG	Array Bias Supply		-1.4		V
Vil	Digital input low level	GND-0.3		0.6	V
Vih ⁽¹⁾	Digital input high level	1.2		VDD1.8+0.3	V
Vol	Digital output low level		GND	0.5	V
Voh ⁽¹⁾	Digital output high level	VDD1.8-0.2	VDD		V
VGN	Gamma feedback signal	0		5	V
Ipix	Average Pixel Current per frame	0			nA
Ipix_inl	Average Pixel Current Integral Non Linearity				%
Ipix_dnl	Average Pixel Current Differential Non Linearity				%

(1) Except for SCL & SDA which can be operated from +1.8V to +5.0VDC

Table 6-4 : AC Characteristics

(Ta = +20°C, GND = 0V, VDD1.8 = +1.8V, VDD5 = +5.0V, VCOM = -2V, VPG = -1.4V, Ipix_avg = 6 nA)

Symbol	Parameter	Min	Typ.	Max.	Unit
SCLK	Video Clock Frequency	44	-	120	MHz
CLK_Duty	SCLK duty cycle	45		55	%
Fhs	Horizontal Sync frequency	30		70	KHz
Fvs	Vertical Sync Frequency	30		65	Hz
Tlo	Line Overscan (% of line time)	3			%
Tfb	Frame Blanking (% of frame time)	1			%
Trst	Reset Pulse Width	100		-	µs
Cin	Digital Pins Input Capacitance		3		pF
Cvpg	Pin VPG Input Capacitance		13.6		nF
Pd VDD5	Average VDD5 Power Consumption (SXGA Mode 60 Hz refresh rate)		160		mW
Pd VDD1.8	Average VDD1.8 Power Consumption (SXGA Mode 60 Hz refresh rate)		25		mW
Pd VPG	Average VPG Power Consumption			1	mW
Pd PDWN	Total Power Consumption in PDWN (sleep) mode		2.5		mW
Ta	Ambient Operating Temperature	-45		+70	°C

Power consumption measured at 60Hz refresh rate, room ambient temperature and with a TV-like monochrome green test pattern that represents an average video mode (See below Figure 5) and a full green field equivalent luminance of 5,000 cd/m²

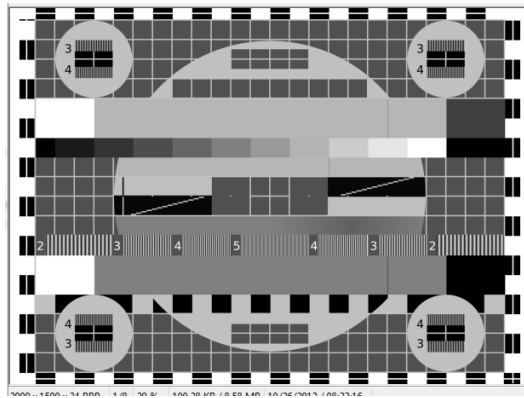

Figure 5: Monochrome Test Pattern

Figure 6 shows the typical room temperature power consumption of the display for different image contents and maximum luminance.

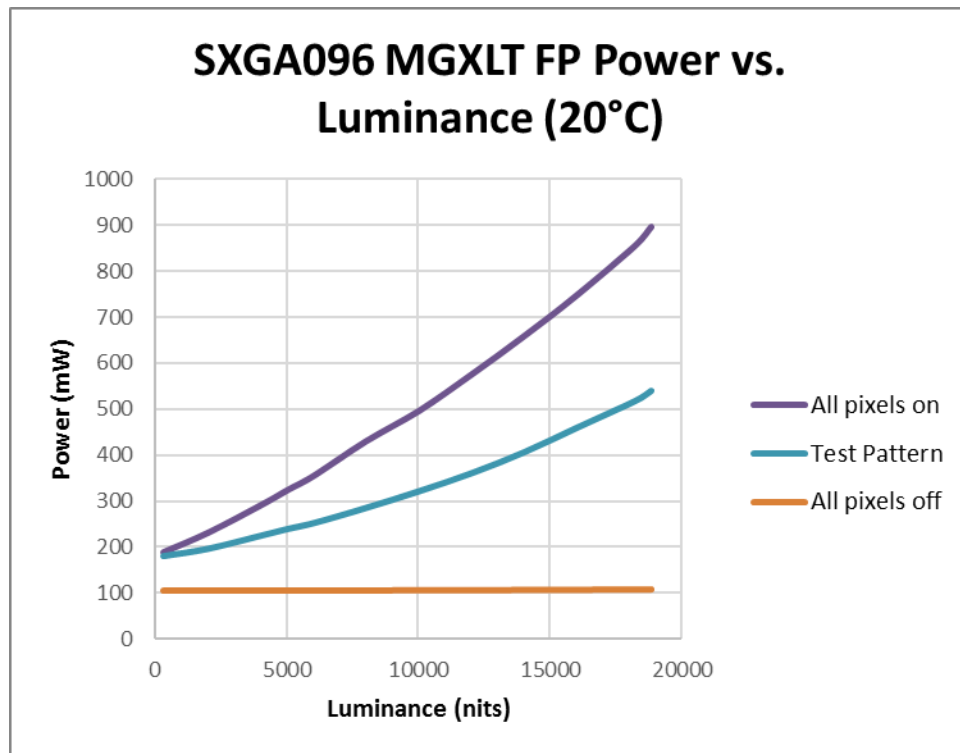

Figure 6: SXGA096 MGXLTFP Power vs. Luminance

Figure 7 shows the typical power consumption (mW) over the operational temperature range (°C) with all pixels on and a room temperature luminance set to 5,000 cd/m²

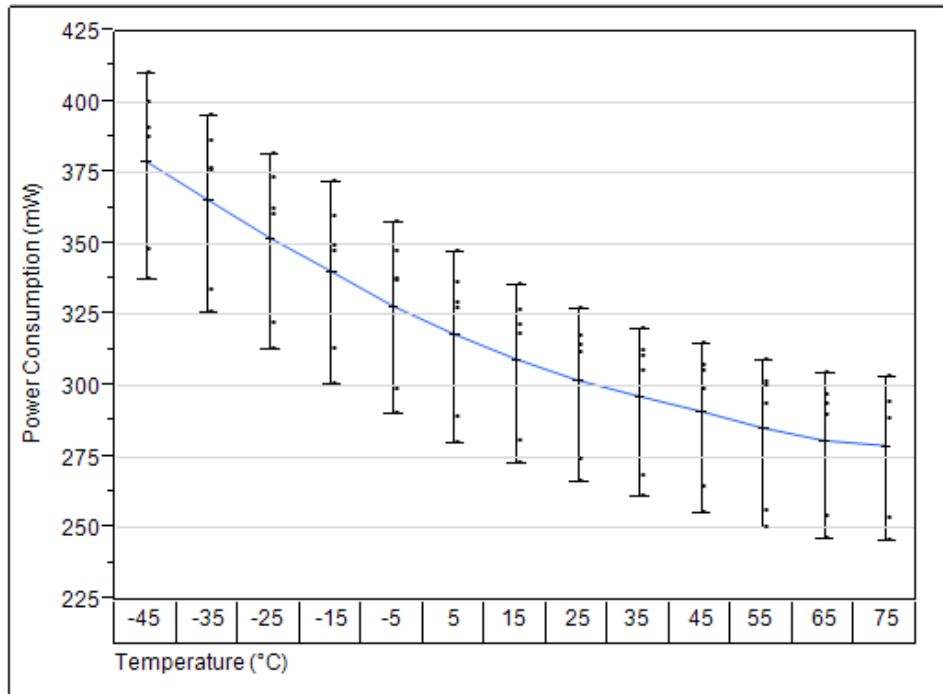

Figure 7: Power vs. Temperature

6.1 Timing Characteristics

6.1.1 Video Input Timing Diagrams

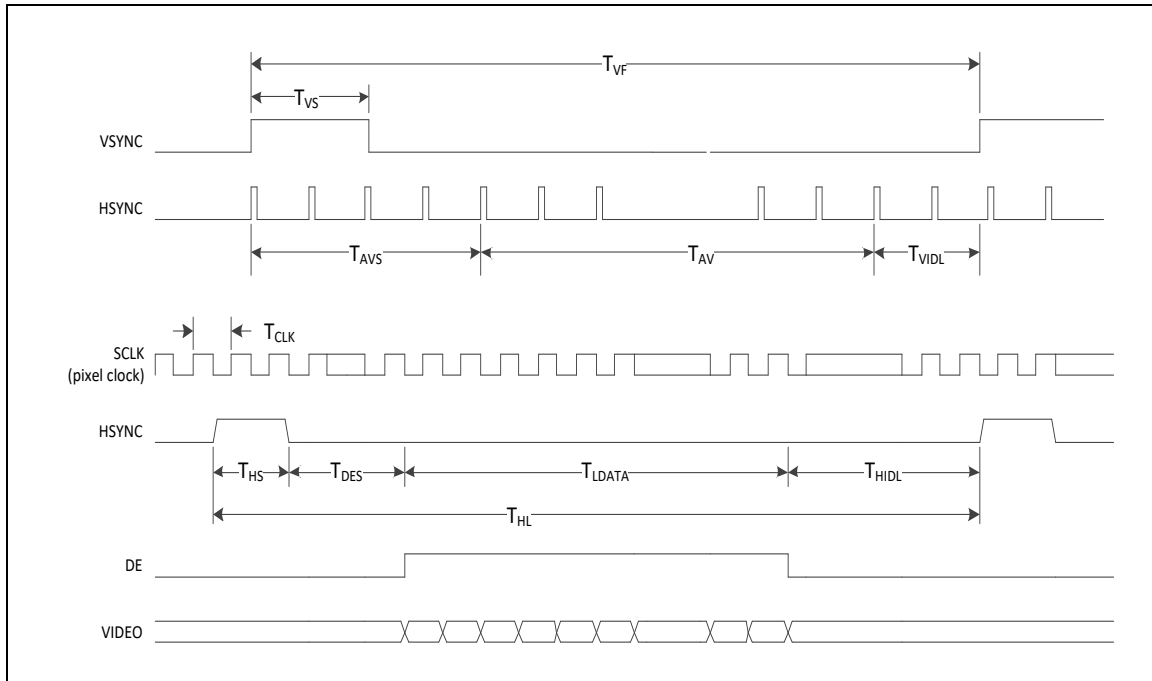

Figure 8: Video Input Timing Diagram

Table 6-5 : Video Input Timing Characteristics

Parameter	Symbol	Min.	Typ.	Max.	Unit
Clock Frequency Clock Period	F _{CLK}		91 ¹	120	MHz
	T _{CLK}		10.98		ns
Clock Duty	D _{CLK}	45		55	%
VSYNC Pulse Width	T _{VS}	2			HSYNC period
Time to Active Video Start	T _{AVS}	5			HSYNC period
Time to Next Vsync	T _{VIDL}	2			HSYNC period
Active Video Lines	T _{AV}	768	1024	1036	HSYNC period
HSYNC Pulse Width	T _{HS}	8			SCLK period
Time to DE Start	T _{DES}	12			SCLK period
Time to Next Hsync	T _{HIDL}	12			SCLK period
Active Video Pixel	T _{LDATA}	782	1280	1292	SCLK period
Line Overscan	T _{HL}	1200			SCLK period

Note 1: SXGA @ 60 0Hz frame rate, Reduced Blanking Mode

6.1.2 Gamma Sensor Timing Diagram

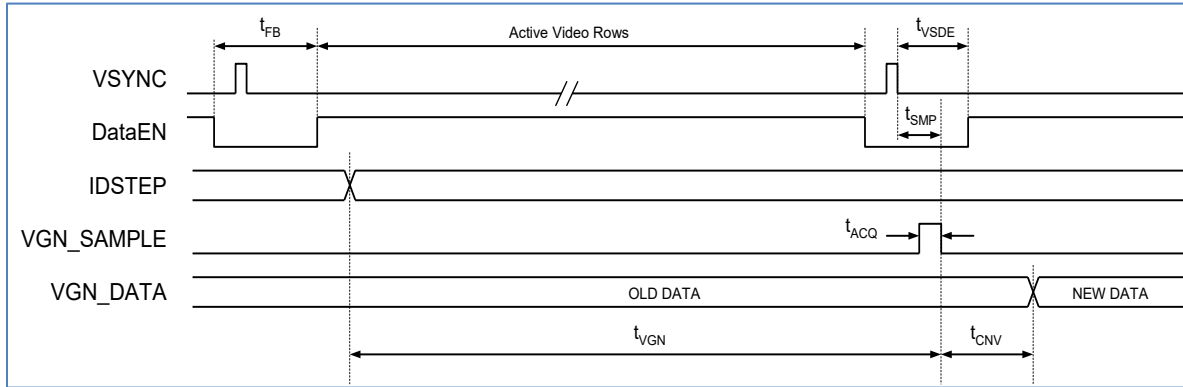

Figure 9: Gamma Sensor Timing Diagram

Table 6-6 : Gamma Sensor Timing Characteristics

Parameter	Symbol	Min.	Typ.	Max.	Unit
IDSTEP to VGN Settling Time	t _{VGN}	10			ms
Frame Blanking (% of Frame Time)	t _{FB}	1			%
VGN Sampling Time	t _{SMP}	t _{ACQ}		t _{VSDE}	
A/D Acquisition Time	t _{ACQ}	20			μs
A/D Conversion Time	t _{CNV}				

7. OPTICAL CHARACTERISTICS

7.1 Room Temperature Characteristics

Table 7-1 : SXGA-096 Monochrome Green XLT Microdisplay Optical Characteristics
Conditions: Ta = +20°C, VDD1.8 = +1.8V, VDD5 = +5V, VPG = -1.4V, Refresh rate: 60 Hz

Symbol	Parameter	Min.	Typ.	Max.	Unit
LMAX	Front Luminance @ max gray level	700	5,000 ⁽¹⁾	>15,000 ⁽²⁾	cd/m ²
	Variability (display to display) ⁽³⁾	0	10	22	%
LMIN	Minimum display luminance @ max. gray level ⁽⁴⁾	-	0.1	0.5	cd/m ²
CR	White to Black Contrast Ratio	1,000:1	10,000:1	> 80,000:1	
CIE White	CIE-X	0.37	0.410	0.430	
	CIE-Y	0.560	0.600	-	
GL	Gray Levels	-	256	256	levels
F _R	Refresh Rate	30	60	85	Hz
FF	Emissive Area/Total Sub-pixel Area		0.69		
U _{LA}	End to end large-area uniformity	85 ⁽⁵⁾			%
S _{VH}	Pixel spatial noise at ½ luminance ⁽⁶⁾ (1STD)			5	%
T _{ON}	Time to recognizable image after application of power			0.5	sec

Note 1: At the center of a display with all pixels on at gray level 255

Note 2: At very high brightness levels (LMAX > 10,000 cd/m²), the lifetime of the display will become significantly shorter than at 5,000 cd/m².

Note 3: When using on-board eeprom values to set IDRf for the targeted luminance (See 9.4.5)

Note 4: Assumes IDRf = 00, DIMCTL = 64 and use of the PWM dimming mode.

Note 5: At gray level 255 and 5,000 cd/m² luminance. Luminance uniformity measured between the nominal values of five 1,000 pixel zones located in the four extreme corners and the center zone of the display.

Note 6: Spatial noise is measured at half the nominal luminance (~2,500 cd/m²) and gray level 255. The measurement is the ratio of the variability (standard deviation) by the mean luminance.

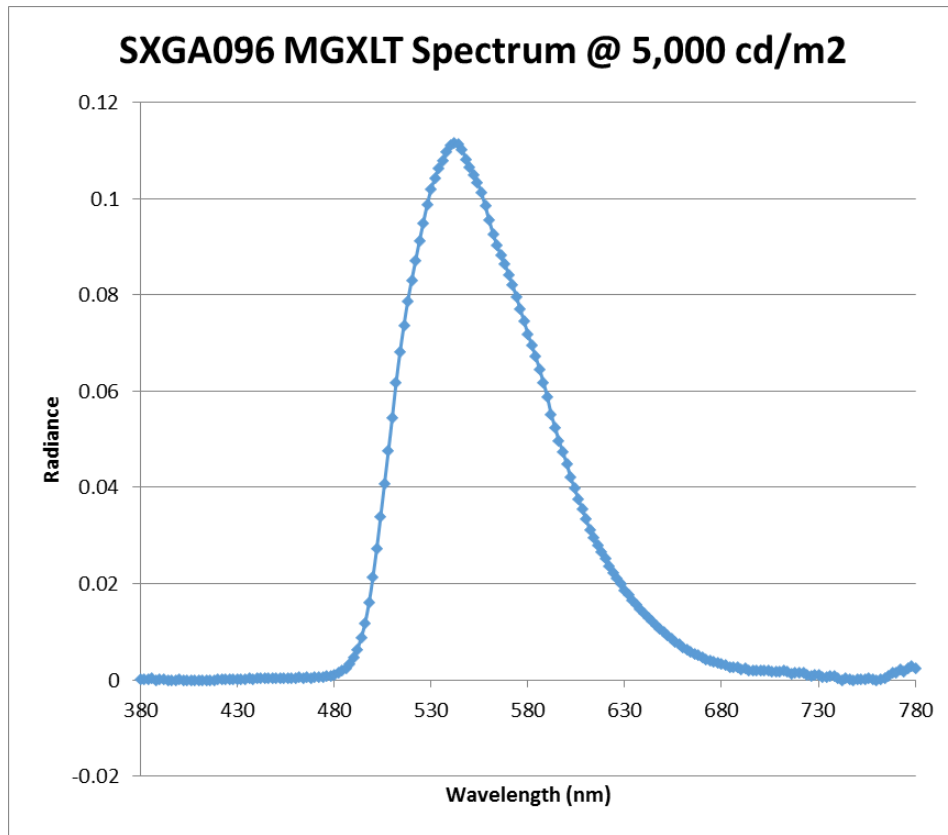

Figure 10: SXGA096 MGXLT Spectrum

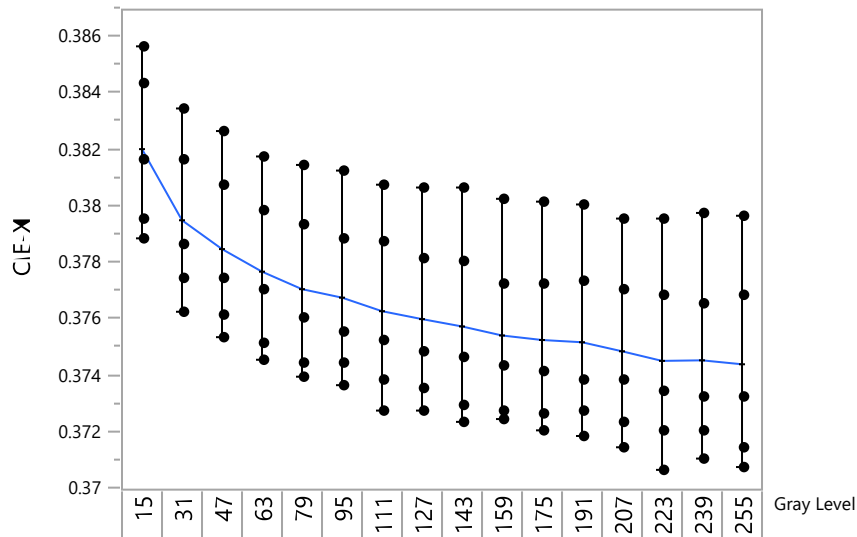

Figure 11: SXGA096 MGCLT CIE-X vs. Graylevel (@5,000 cdm⁻²)

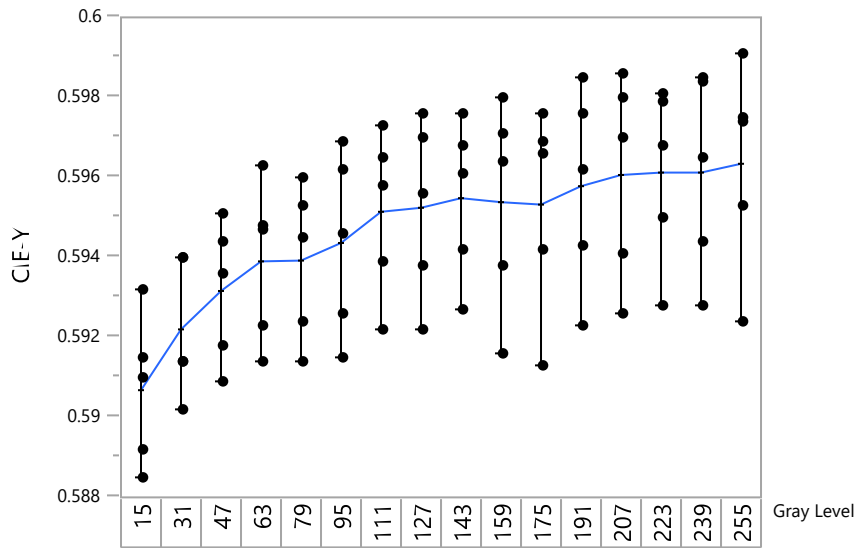

Figure 12: SXGA096 MGXLT CIE-Y vs. Gray Level (@ 5,000 cdm⁻²)

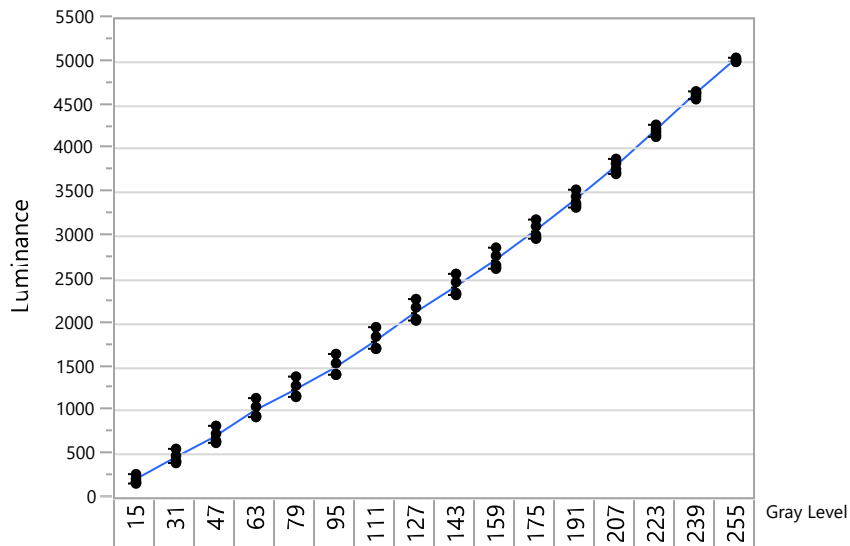

Figure 13: SXGA096 MGXLT Luminance vs. Gray Level

7.2 Characteristics over full operational temperature range (-46°C to +71°C)

Figure 14 below shows the luminance regulation over the full operational temperature range with the display operated with 100% of pixels turned on at gray level 255 and a room temperature luminance set to 5,000 cd/m².

The typical variability, defined as (Max-Min)/(Avg) is 9.5%

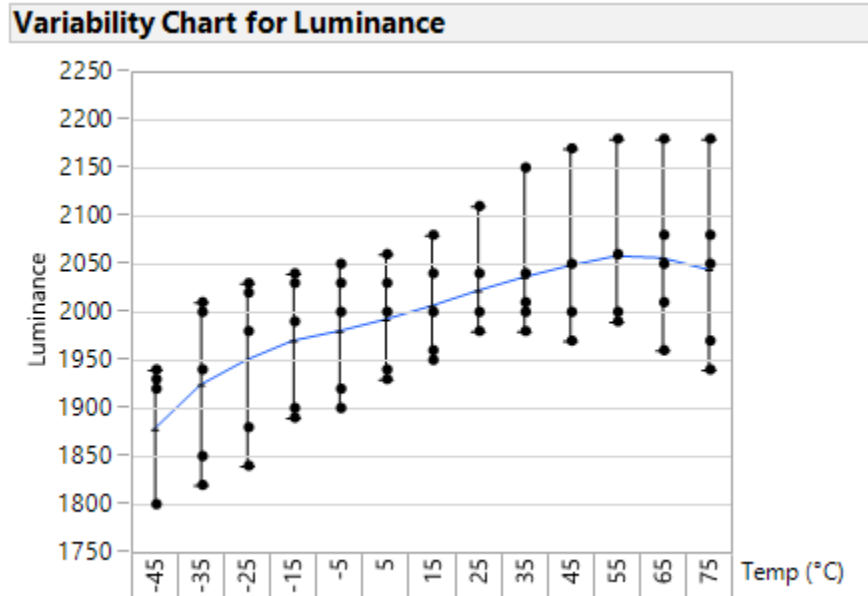

Figure 14: Luminance stability vs. Temperature

Figure 15 and Figure 16 show the stability of the green monochrome green point (CIE-X and CIE-Y) over the full operational temperature range at luminance set to 5,000 cd/m² at room temperature.

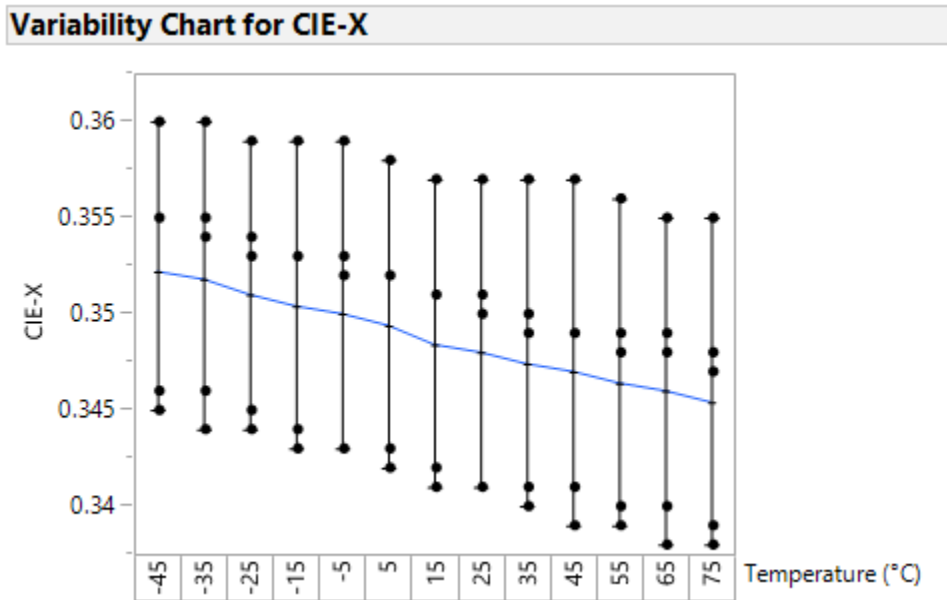

Figure 15: Green CIE-X vs. Temperature @ 5,000 cd/m²

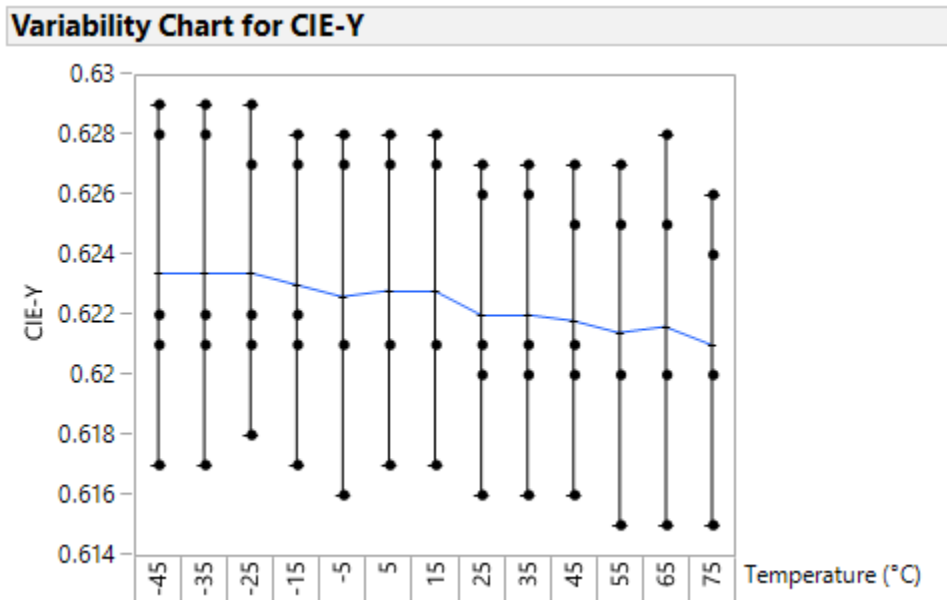

Figure 16: Green CIE-Y vs. Temperature @ 5,000 cd/m²

8. MECHANICAL CHARACTERISTICS

Connectors J1

Manufacturer: Hirose
Manufacturer Part Number: DF12NB(3.0)-30DP-0.5V(51)

Mating Connector Information

Manufacturer: Hirose
Manufacturer Part Number: DF12NB(3.0)-30DS-0.5V(51)

Weight: < 3 grams
Printed Circuit Board Material: FR4
Printed Circuit Board Tolerances: ± 0.25 mm (both axes)

Note

DF12D(3.0)-30DP-0.5V has been obsoleted by the manufacturer.
The replacement connector implementation started in January 2022.
The replacement connector color is black, and is form/fit/function compatible with the older part number.



Older version



Current version

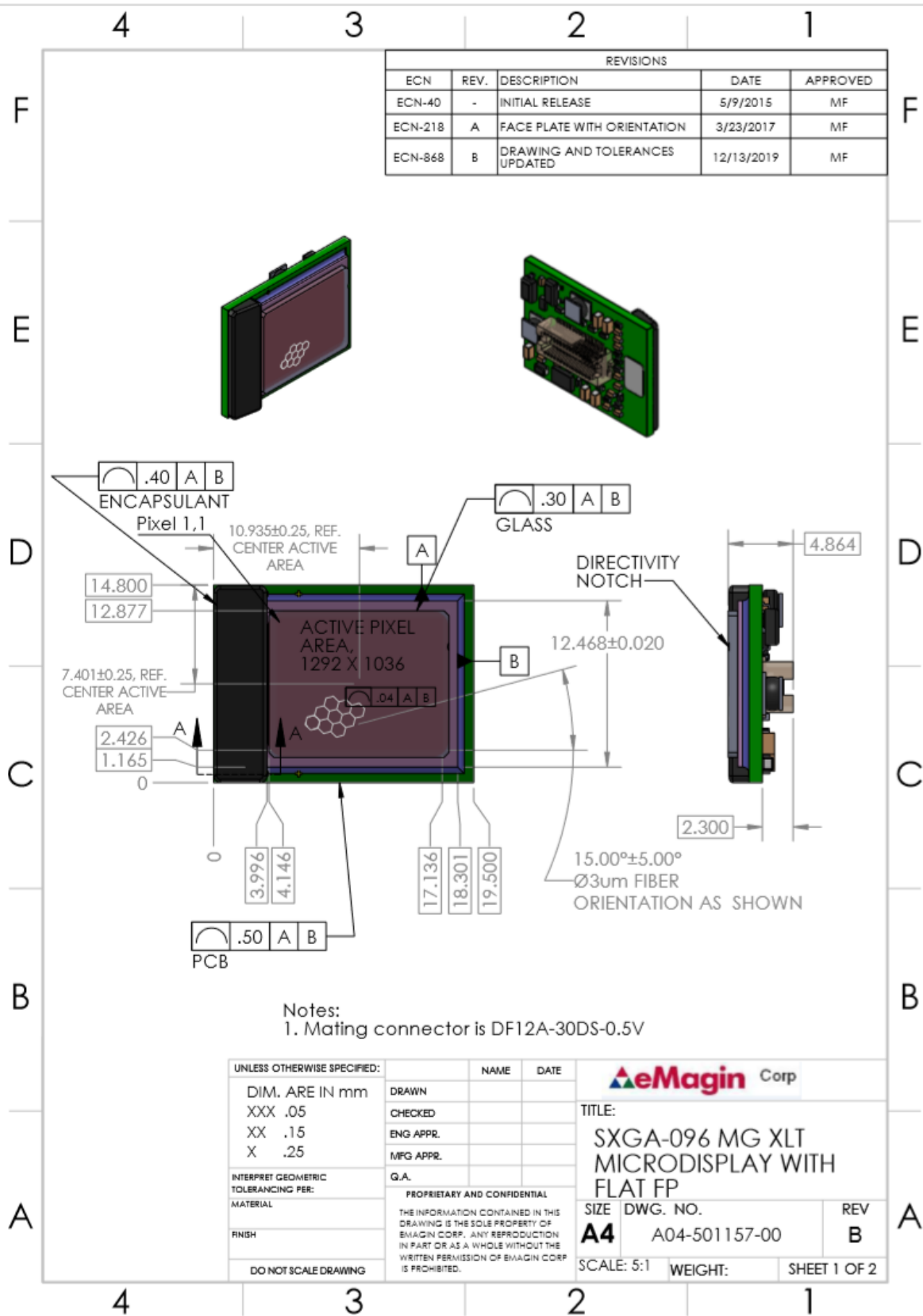

Figure 17: SXGA-096 MG XLT Microdisplay Assembly

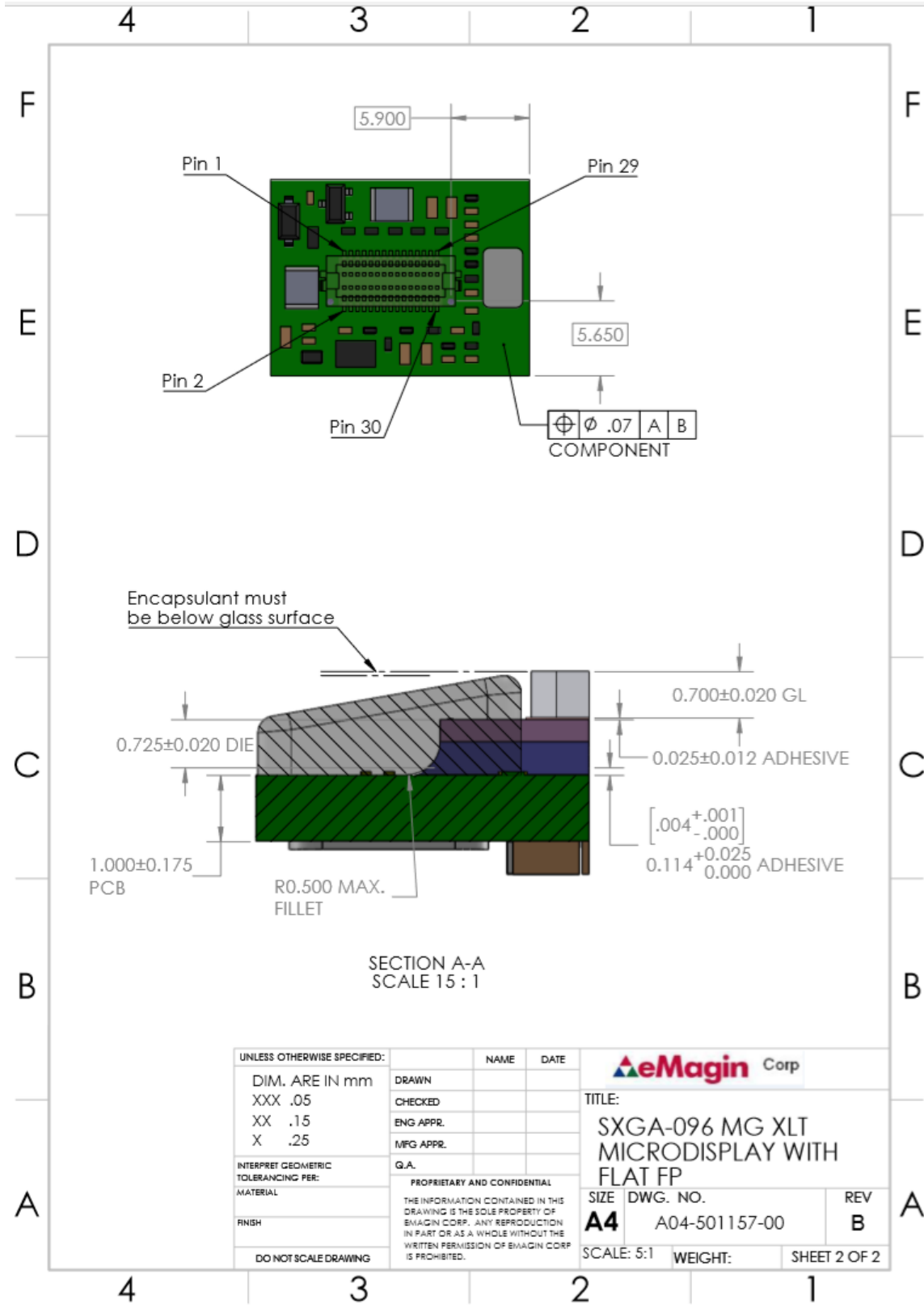

Figure 18: SXGA-096 Microdisplay Assembly - Detail

Carrier Board Schematic

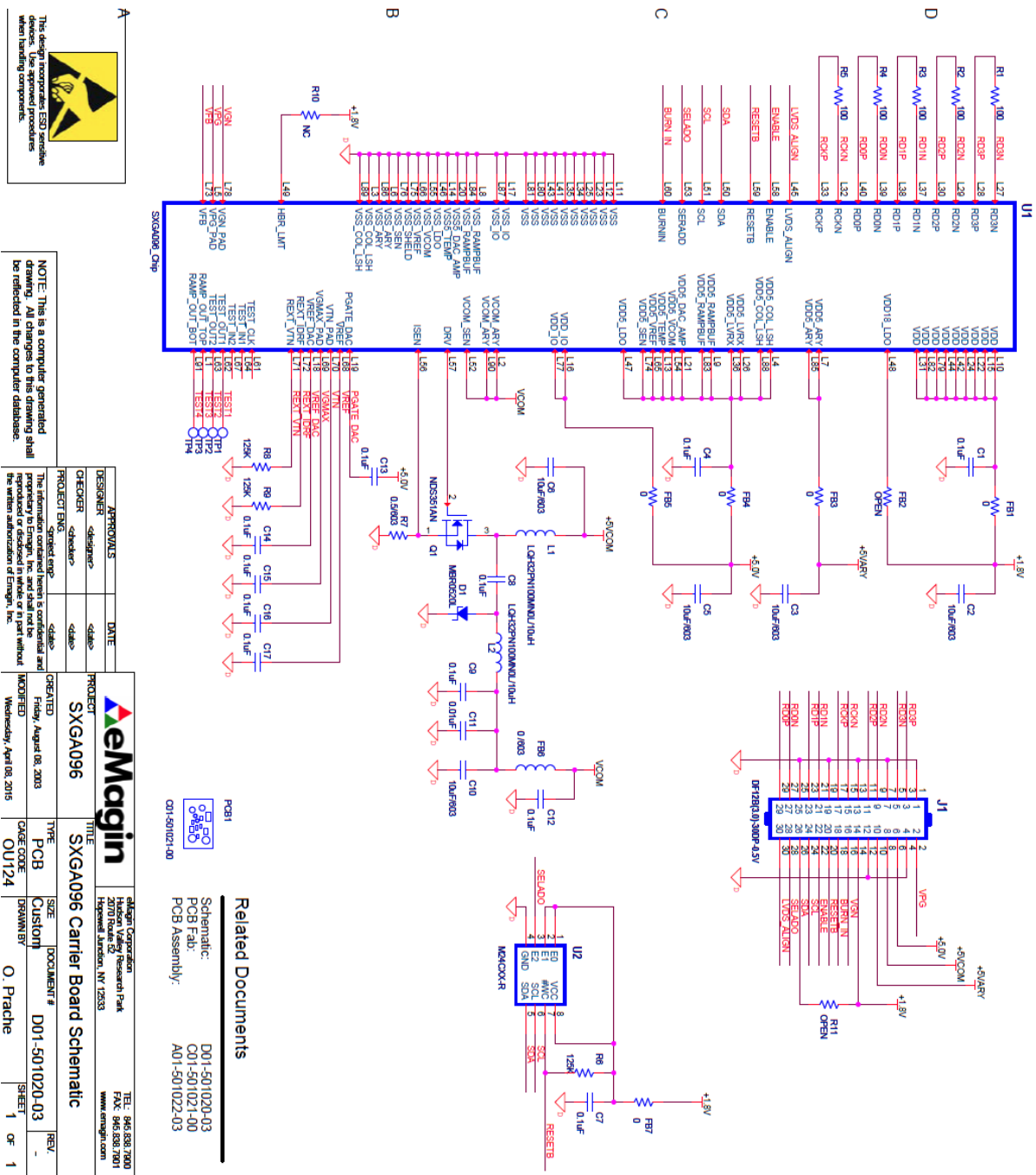

Figure 19: SXGA096 Carrier Board Schematic

9. DETAILED FUNCTIONAL DESCRIPTION

9.1 Video Interface

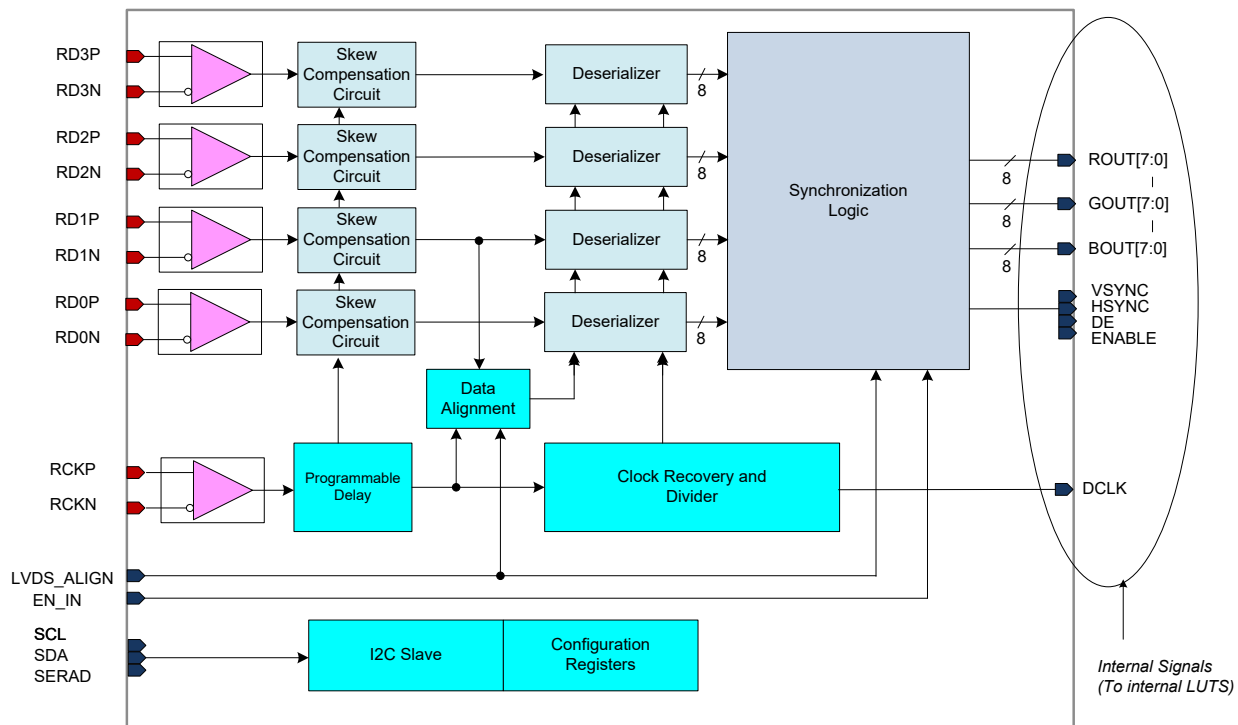

Figure 20: LVDS Receiver Block Diagram

The video interface signals are composed of 4 data pairs and one clock pair, which are the low voltage differential signaling (LVDS), and one control signal (LVDS_ALIGN), which is a CMOS signal. It is different from the industry standard LVDS interface protocols. The receiver input PADS expect the standard LVDS output signaling, but the serialization and protocol is different. The LVDS data pairs should be 8-bit serialized data. The LVDS clock also should be the serialized signal in the same way to the data channel with toggle pattern instead of PLL clock. It always should be 4 times faster than the pixel clock. The LVDS receiver uses both edges of clock. And it has a special skew compensation circuit to harmonize the skews among the 4 data pairs and the data alignment logic. The LVDS receiver expects the special skew compensation patterns through all LVDS channels including the clock channel when power is applied and the alignment patterns to identify the MSB of the 8-bits serial data at every VSYNC at least. (Refer to Appendix B)

Figure 21 shows how the LVDS channels map into data (R,G,B) and control signals

Note that a monochrome white implementation at reduced power is possible by using only channels RD2 and RD3 and setting bit 6 of register 2 (DISPMODE) to 1.

Bits	LVDS Data Channel			
	RD1	RD2	RD3	RD4
6	R7	G6	R0	B5
5	R1	G5	DE	B4
4	R6	G1	HSYNC	B3
3	R5	G0	ENABLE	B1
2	R4	G4	VSYNC	B0
1	R3	G3	B7	B2
	R2	G2	G7	B6
0	VDMY1*	VDMY2*	VDMY3*	VDMY4*

* : Dummy bits for line balance

Figure 21: LVDS Data Map

Table 9-1: Example LVDS Interface Timing

	Video Format		LVDS Interface		
	Pixel Clock MHz	Video Data	No. of Pins (pairs w. clock)	LVDS Data rate Mbps	LVDS Clock MHz
SXGA (60Hz) 1280X1024	91.00	24bit	5	728.00	364.00
HD720 (60Hz) 1280X720	74.50	24bit	5	596.00	298.00

Table 9-2: LVDS Characteristics

Symbol	Parameter	Conditions	Min	Typ	Max	Units
V_{CM}	Common Mode Input Range		1.0		1.8	V
V_{TH}	Differential Input High Threshold	$V_{CM} = +1.2V$			+100	mV
V_{TL}	Differential Input Low Threshold		-100			mV
I_{IN}	Input Current	$V_{IN} = 1.8V$			± 10	μA
		$V_{IN} = 1.0V$			± 10	μA
F_{TCLK}	LVDS Clock Frequency	SXGA FR=60Hz		364	400	MHz
TT_{TCLK}	LVDS Clock Transition Time	F = 400MHz			0.68	ns
DC_{TCLK}	LVDS Clock Duty Cycle	F = 400MHz	45		55	%
SKWMG	Receiver Skew Margin with Deskew	F = 400MHz	200			ps

9.2 D/A Conversion

In this design the conversion of the video input signal into an analog drive signal at the pixel is carried out in a two-step process during each horizontal clock period. The digital input video data is first transformed into a precise time delay based on counts of the global RAMP clock. Second, the time delay triggers the column switch to sample the voltage of a linear ramp and to store the analog value on the column line capacitor. The selected pixel circuit copies the analog data and uses it for driving the OLED diode until it is refreshed during the next frame period.

A block diagram of one column drive circuit is shown in Figure 22. The 1292 Display registers form a line memory that facilitates a pipeline mode of operation in which video data is converted to analog form and sampled by the pixels in row M during the same line period that video data for row M+1 is loading into the LOAD registers. At the end of each line period the data in the LOAD registers is transferred in parallel into the DISPLAY line memory. The externally supplied SCLK clock is used for both loading input data into the chip and for advancing the global column counter. There is a maximum latency of 2 line periods before data is displayed.

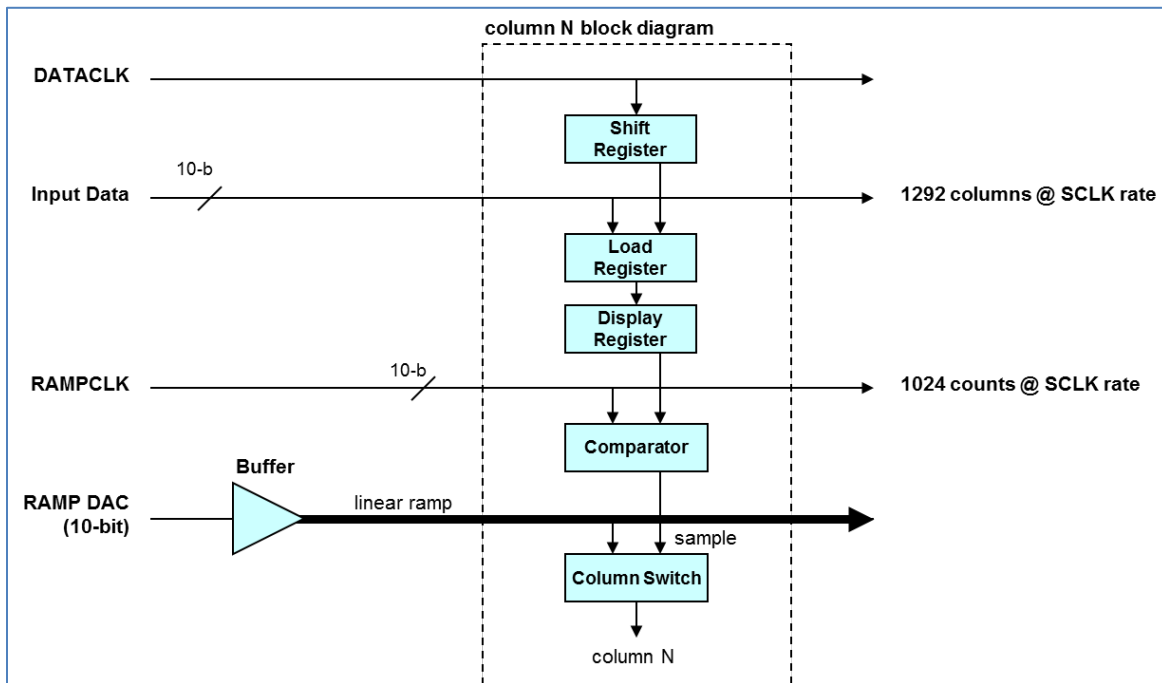

Figure 22: Data sampling for Column N

A timing diagram for the data sampling process is shown in Figure 23 . The internal Ramp Generator operates at the HSYNC frequency and outputs a linear ramp with a slow rise-time and a fast reset capability that is buffered and applied to all the pixel array columns simultaneously. The RAMP signal starts synchronously with HSYNC (after a delay) with a positive slope from a zero voltage level and rises to a voltage near the VDD5 rail after 1024 SCLK clock cycles as determined by a 10-bit counter. The

start position of the RAMP can be adjusted via register bits RAMPDLY, its peak value can be set using register VDACMX, and the duration of the flyback transition can be selected between two options by the FLYBTIME bit in register RAMPCTL.

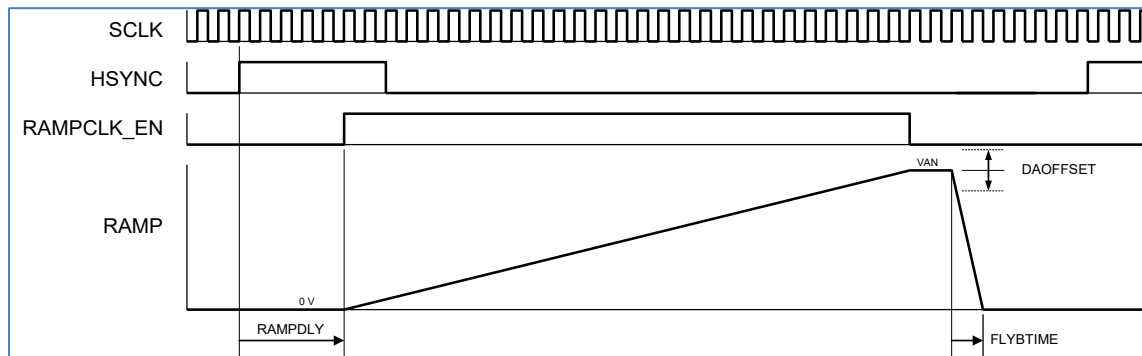

Figure 23: Timing diagram for column data sampling

9.3 Format and Timing Control

Various control signals for the horizontal and vertical sequencers that are needed to implement the specified video formats are generated in the Timing & Control Logic block. The specific timing parameters are set by registers VINMODE, DISPMODE, LFTPOS, RGTPOS, TOPPOS and BOTPOS using the serial interface.

The display starts up with the array in the off-state (black) by default and requires a command to the DISPOFF register bit via the serial interface to turn the display on. This provides the user with an opportunity to change the default startup conditions before a video image is displayed.

Bi-directional scanning is supported in both orientations via the DISPMODE register. Bit VSCAN sets the vertical scan direction, and bit HSCAN sets the horizontal scan direction.

9.3.1 Vertical Position Control

To support the vertical positioning of the display within the extra 12 pixels provided on each column of the array, an on-chip shift register function is provided in the Row sequencer logic, and controlled by registers TOPPOS and BOTPOS. The starting row for the active video is determined by register TOPPOS and the ending row by register BOTPOS, which are set by default so the active window in SXGA mode is vertically centered in the array. The Vertical positioning logic will blank rows at the beginning and end of each frame of data to allow a vertical image shift of up to 12 pixels in steps of 1 or 2 pixels in SXGA mode.

9.3.2 Horizontal Position Control

To support the horizontal positioning of the display within the extra 12 pixel provided on each row of the array, an on-chip shift register function is provided after the LUT block, and controlled by registers LFTPOS and RGTPOS. The Horizontal Shifter adds black pixel data to the beginning and end of each line of data to allow a horizontal image shift of up to 12 pixels in steps of 1 pixel in SXGA mode.

9.3.3 Interlaced Modes

Bits SCMODE in the DISPMODE register are used to select either progressive (default) or interlaced modes.

Field status in interlaced mode is provided via the ENABLE input pin. The state of this pin is latched on the falling edge of VSYNC. When register bit SET_FIELD = "0" then a logic low at the ENABLE pin indicates that Field 1 (odd field) is active, and a logic high indicates that Field 2 (even field) is active. The opposite states are indicated when SET_FIELD is set to 1.

9.3.4 Stereovision Mode

The SXGA-096 is designed with binocular stereovision applications in mind. As a result of the fast OLED response time and the presence of a storage capacitor at each pixel, it has been verified that the microdisplay can operate at low refresh rates without showing flicker.

This allows the displays to be used with a frame or field sequential (more generally known as time sequential) stereovision mode using a single video input channel, and therefore providing a simple means to leverage the capabilities of PC compatible computers using stereo compatible graphics adapters, such as the NVidia GeForce series. The frame sequential stereovision mode supported should follow the Video Electronics Standards Association (VESA) Connector and Signal Standards for Stereoscopic Display Hardware. This standard is available from VESA at www.vesa.org.

The ENABLE input pin allows for a direct implementation of the VESA standard without additional external components. The microdisplay can be programmed for either an active high or low Enable, allowing a single signal to be used with two displays. In such a configuration, one display scans and displays while the other one holds and displays.

The ENABLE input acts, when set low, as a mask for HSYNC and VSYNC. It does not blank the display but prevents it from acquiring another frame of data until released. This is a real time input. The active state (high or low logic level) is programmed by the SET_ENABLE bit in the VINMODE register.

The 3D-MODE bit of the DISPMODE register will be used to set either Time Sequential mode to activate the stereovision mode of operation (1) or Normal (non-3D) operation (0).

Frame Sequential Mode:

In Time Sequential Mode each video frame contains information for either the left or right eye. When 3D-MODE="1" the SCMODE bits in the DISPMODE register are set to Progressive Scan Mode (00H) for frame sequential mode. The following description for Frame Sequential operation assumes the source is in compliance with the VESA standard mentioned above, where the data for the left eye is provided while the Enable signal is at the logic high level, and the data for the right eye display is provided while the Enable signal is at the logic low level. The stereovision mode is controlled by both the Enable input pin and by the SET_ENABLE bit of the VINMODE register. The Enable input signal is sampled into the circuit by a flip-flop clocked on the falling edge of VSYNC and the sampled value is used for the next frame. (The Enable signal is generated by the graphics software and may not be synchronized to the VSYNC signal).

To activate the stereovision mode, the right eye display needs to be configured with Enable active low (SET_ENABLE= "0"). This will allow the right eye microdisplay to hold the previous frame while the Enable input is high. The left eye display must be configured with Enable active high (SET_ENABLE="1"). Thus the two Enable inputs can be tied together to the incoming Stereo Sync signal provided by the graphics adapter (or other custom source).

Field Sequential Mode:

In Field Sequential Mode each video field in an interlaced image contains information for either the left or right eye. Consequently, the resolution is reduced in half for each display.

When 3D-MODE="1" the SCMODE bits in the DISPMODE register are set to either Interlaced or Pseudo Interlaced Mode to activate field sequential mode. The operation of the Enable input pin and the SET_ENABLE bit will be similar to Frame Sequential Mode except that now the Enable input toggles at the field rate. The polarity of the field corresponding to the active state of the ENABLE input will be set by the SET_FIELD bit in the VINMODE register. When SET_FIELD="0" the odd field is applied during the active state for ENABLE, and the even field is assumed during the active state for ENABLE when SET_FIELD="1".

For standard WVGA operation, the SET_ENABLE bit needs to be set to 0 (logic low), which is the power-on default value, and the Enable pin input needs to be tied to Ground.

9.3.5 Row Duty Rate Control

The duty rate for a row of data is defined as the fraction of a frame period during which the pixels maintain a programmed value; for the remainder of the frame period the pixels will be driven to black.

A Row Reset function is provided in the SXGA096 to allow the duty rate of rows to be controlled between 0 and 100% (default condition). The register ROWRSET[9,0] is used to set the number of Hsync cycles during which the pixel data is driven to black during a frame period. For ROWRSET=0 the pixel

data is never driven to black and the duty rate for pixel data is equal to 100% (default). For ROWRSET=W the pixels in any row are driven to black for the final 2*W Hsync cycles in an active frame period.

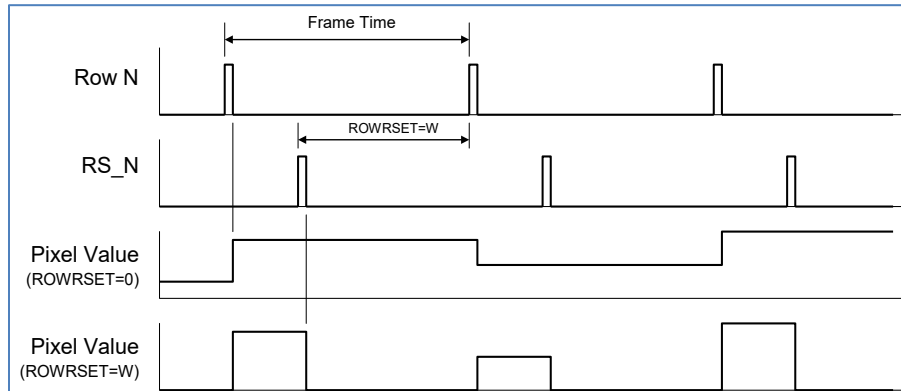

Figure 24 : Timing diagram showing Row Reset functionality.

The operation of the Row Reset function is depicted in the timing diagram shown in Figure 24. All the pixels contained in ROW N are programmed during the Nth horizontal line scan following the initialization line scans which occur at the beginning of a video frame. Normally this pixel data is stored in the pixel and remains unchanged until it is refreshed during the next frame period. When the Row Reset function is activated, the pulse RS_N is generated at a position determined by the value of register ROWRSET. For example, when the register value is equal to W the rising edge of RS_N occurs exactly 2*W Hsync cycles after the programming cycle for ROW N. The pulse RS_N sets all the pixels in ROW N to black until the next programming cycle. All rows in the array will operate at the same duty rate. As a result the duty rate for all the rows in the pixel array will be given by

$$ROW_DUTY = \frac{2 * W * T_{HSYNC}}{T_{FRAME}}$$

This function can be used to control dimming (see section 9.4.5) to extend the display dimming range. A side benefit of this function, when used for dimming, is that no gamma update is needed when dimming is done exclusively with the Row Reset function.

Another use of this function is to reduce motion artifacts: the net visual effect of limiting the on-time of a given row is a reduction in visual persistence. This allows the eye to “forget” the state of the row prior to its update with potentially new information, and leads to the perception of a smoother motion when an object in the image changes position from frame to frame.

The exact value of the Row Reset registers for this function are application dependent and the user must determine what constitutes an acceptable configuration.

9.4 Sensor Functions

9.4.1 Temperature Readout

An on-chip temperature sensor provides continuous device temperature information via the serial interface. The sensing circuitry allows for calibration at power-up via dedicated registers, TREFDIV[5,0] and TEMPOFF[7,0]. The temperature reading is digitized on-chip and stored in a dedicated register, TEMPOUT[7,0]. A register bit, TSENPD in register ANGPWRDN, is able to power down the sensor.

The temperature sampling period is controlled by register TUPDATE[7,0] which allows the temperature reading to be updated between every 50msec to 4.25sec when operating at a 60Hz frame rate.

9.4.2 Luminance Regulation Sensor

Register VGMAX[7,0] controls the pixel drive voltage used for regulating the maximum luminance value. By default this level is set to about 4.95V when the VDD5 supply is equal to 5V to avoid saturating the video buffers. It can be adjusted over a range of 4V to 5V.

The default value is 4Dh and does not have to be changed in most cases.

Register VDACMX[7,0] is used to set the maximum value of the internal Ramp DAC generator. This value should match the internal VGMAX setting for best luminance accuracy and control. The optimum setting has been determined by measurements to be 7A for normal operating conditions. Refer to section 12.12 for more detail.

9.4.3 Pixel Bias Sensor

Register BIASN[2,0] sets a bias current for the OLED array in order to achieve improved control of black level and monochrome white saturation at the expense of a small increase in power consumption. In the default setting (BIASN=1) the bias contributes to a 10mW increase of power consumption for the array. It is recommended to use the BIASN=3 setting for best performance.

9.4.4 Luminance Control (Dimming)

A variable luminance level is achieved by controlling the maximum pixel current while maintaining the largest possible dynamic range. Dimming control for the display is effected by adjusting the 7-bit register DIMCTL via the serial interface to provide 128 linear steps in brightness ranging from near zero to the maximum level set by register IDRFB. This functionality is only available for VCOMMODE=0 or 1.

The bits IDR_F_COARSE in register IDR_F provide a coarse adjustment of the maximum luminance level, while the IDR_F_FINE bits enable the coarse level to be fine-tuned. Figure 25 shows the typical luminance output at gray level = 255 in a monochrome white display for various settings of the IDR_F and DIMCTL registers.

Due to the implementation of the coarse and fine bits, there is a duplication of values for IDR_F at the lower range:

The luminance will be the same for IDR_F = [0x10:0x1F] and IDR_F = [0x20:0x2F]. Figure 25 below illustrates this behavior.

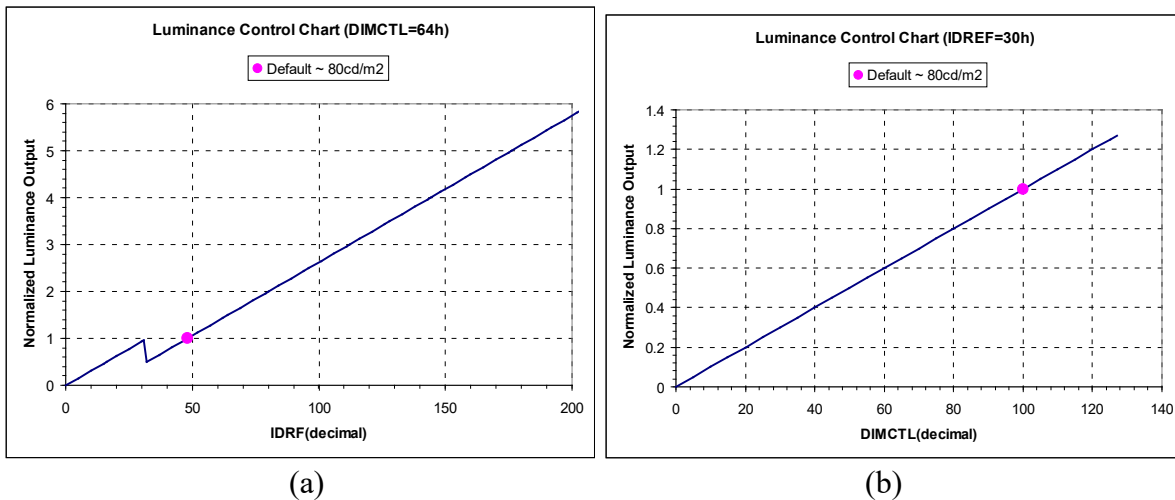

Figure 25: Typical maximum luminance for various IDR_F (a) and DIMCTL (b) settings

9.4.5 Luminance Setting

The SXGA-096 microdisplay luminance can be set to an absolute value using information included in the on-board eeprom at addresses 8Eh to 90h.

The luminance is a linear function of IDR_F for values of IDR_F greater than 32 (decimal code.) that can be expressed as:

$$L = \text{slope} \times \text{IDRF (decimal)} - \text{origin}$$

The information in registers 8Eh to 91h provide the slope and intercept values that govern the Luminance vs. IDR_F linear equation.

Register 8E provides the integer part of the slope

Register 8F provides the fractional part of the slope: the slope values range from 00 to 99

Registers 90 and 91 provide the origin value (Theoretical luminance value for IDR_F = 0. It is theoretical because the linear equation is only valid for IDR_F >20h (32 decimal)). Values for Origin range from 0 to 65535.

Register 90 is the low-byte register

Register 91 is the high-byte register

The slope and origin values are calibrated for each display. With these values, the calculated luminance is in cd/m^2 units (nits).

The accuracy of the calculated value is smaller than or equal to 3% for luminance levels up to 5,000 cd/m^2 , and better than 7% beyond 5,000 cd/m^2 .

This allows precise matching between displays when used in a binocular application, as well as exceptional consistency of performance from display to display.

9.4.6 Gamma Correction Sensor

The gamma sensor is provided as an aid to generating a linear optical response from the SXGA-096 display system. As described previously, an external 256-entry look-up-table is required to transform input video data into a gamma-corrected data signal for driving the microdisplay input port. The SXGA-096 display generates an internal real-time representation of the gamma correction curve for the current operating conditions. This representation is in the form of an analog voltage waveform which can be sampled one point at a time at the VGN pin for eight specific values on the curve. A specific value VGN_i , corresponding to one of 8 internally fixed grayscale levels GL_i , is selected by setting bit IDSTEP in register GAMMASET via the serial port. The VGN signal is internally fixed for a full-scale output range of $VDD5/2$. Eight sequential measurements are required to complete the gamma table. The gamma table can then be used to reconstruct an approximation of the ideal gamma correction curve using piece-wise linear interpolation, or by employing a curve fitting algorithm to achieve more accuracy if desired. This function is only available for VCOMMODE=00h.

An external A/D converter is required to convert each VGN measurement into digitized form and to store the values in a microcontroller for further processing. A full frame period following a change in the IDSTEP bit should be provided to allow the VGN signal to settle before sampling it to 10-bit precision by the external A/D converter. It is recommended to sample the VGN signal during the frame blanking interval for best results.

The VGN pin has a 25 Ohm nominal output impedance and can source/sink up to 200 mA

The VGN readings are normalized and converted to a 10-bit full-scale word $DVGN_i[9,0]$ using the following expression:

$$DVGN_i[9,0] = \frac{VGN_i}{VGN_{MAX}} * 1023$$

Where VGN_{MAX} is $VDD5/2$. Each of these data values must be further multiplied by a correction factor CF_i to obtain the Gamma table coefficients as follows:

$$GC_i[9,0] = DVGN_i * CF_i$$

where empirically determined values for factor CF_i are given in Tables 10-3 and 10-4.

The correction factors need to be adjusted depending on the luminance level in order to produce the best response.

Table 9-3: Correction Factor values for $L \sim 5,000 \text{ cd/m}^2$

CF0	CF1	CF2	CF3	CF4	CF5	CF6	CF7
0.88	0.909	0.929	0.953	0.973	0.987	0.992	1

Table 9-4: Correction Factor values for $L \sim 500 \text{ cd/m}^2$

CF0	CF1	CF2	CF3	CF4	CF5	CF6	CF7
0.801	0.840	0.859	0.888	0.908	0.936	0.959	1

Using the derived values for GC_i and their corresponding grayscale coordinates GL_i , the 8-entry Gamma Correction table consisting of data points $Q_i = (GL_i, GC_i)$ can be constructed. The outcome of a typical gamma sensor measurement and calculation procedure is shown in Table 10-5, for a green luminance $\sim 5,000 \text{ cd/m}^2$.

Table 9-5: Sample Gamma Correction Table

i	1	2	3	4	5	6	7	8
IDSTEP[0]	0h	1h	2h	3h	4h	5h	6h	7h
VGN_i (volt)	1.865	1.912	1.935	1.975	2.056	2.153	2.310	2.500
GC_i (dec)	504	534	562	603	664	743	862	1023
GL_i (dec)	2	4	8	16	32	64	128	255

The full 256-word LUT is derived from the Gamma Coefficient Table using linear interpolation to generate intermediate data points as illustrated in Figure 26. The input to the LUT for each monochrome green of the video source is represented by the 8-bit signal $VIN[7,0]$, and the output of the LUT (which is also the input to the microdisplay) is represented by the 10-bit signal $DIN[9,0]$. For example, the Y coordinate for the intermediate point $Q(x, y)$ on the line segment formed between the gamma table points Q_6 and Q_7 is obtained by:

$$Y = Y_6 + (Y_7 - Y_6) * \frac{(X - X_6)}{(X_7 - X_6)}$$

The intermediate points for other line segments are found in similar fashion. A software routine in the system microcontroller is used to perform the necessary calculations before loading it into the data-path

LUTs in the microdisplay. A buffer LUT is used in the microdisplay to temporarily store the data as it is transferred from the microcontroller via the serial port. When the buffer LUT is full, the data can be rapidly transferred to the data-path LUTs during a frame blanking time to avoid disturbing the displayed image.

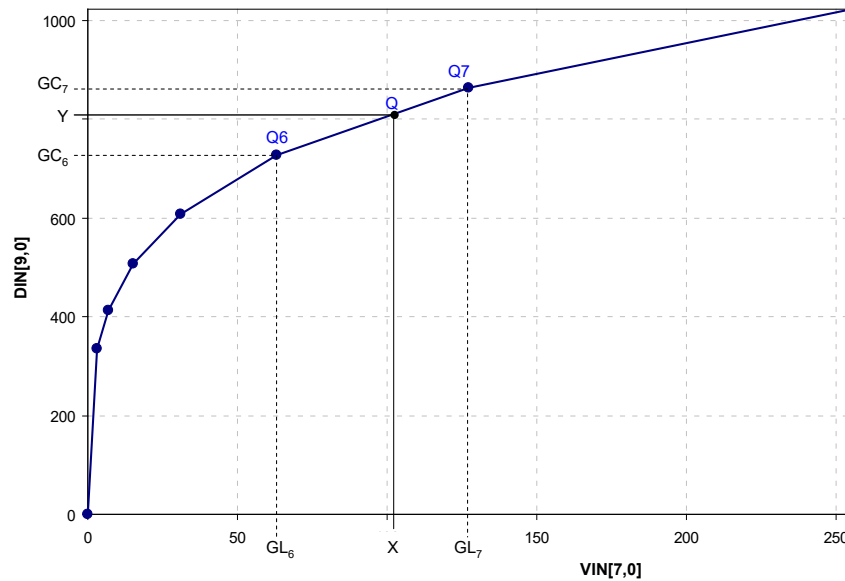

Figure 26 : Generating intermediate points by linear interpolation

A smooth transition of the gamma curve at the lowest gray levels is essential for best performance of the display at the black end of the gray scale. Refer to Figure 27 for an illustration of the recommended approach for calculating the gamma curve at low gray levels. The LUT data points for gray levels 1 to 4 can all be generated by linear extrapolation from the gamma points Q1 and Q2. The LUT data point for gray level 0 (also defined as Q0) is a fixed value that is user-defined, and normally should be set to a very low value, e.g. 1, to ensure the best black level. The value for Q0 is shown on the graphical interface screen supplied with the SXGA-096 design reference kit for user convenience. It is not affected by the gamma sensor signal and can only be changed manually by user input.

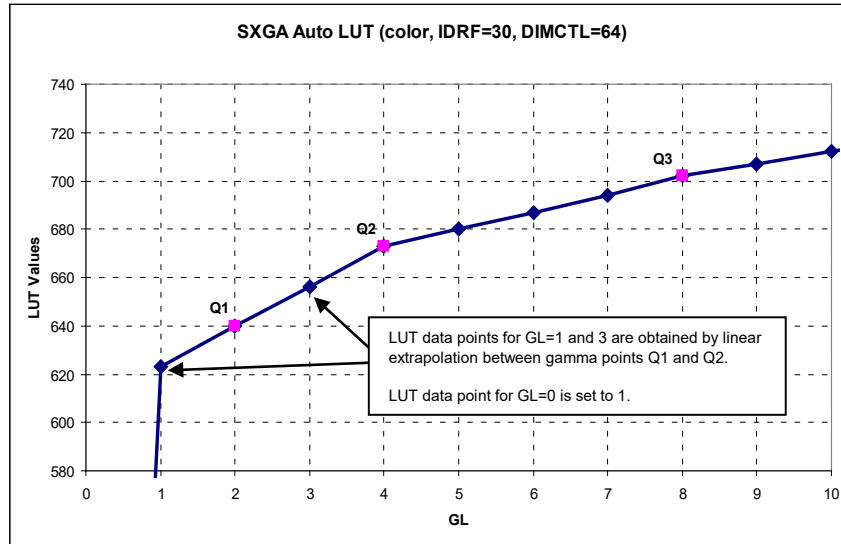

Figure 27 : Gamma curve at low gray levels

Figure 28 shows a typical gray scale response for a Gamma = 1 at 5,000 cd/m²

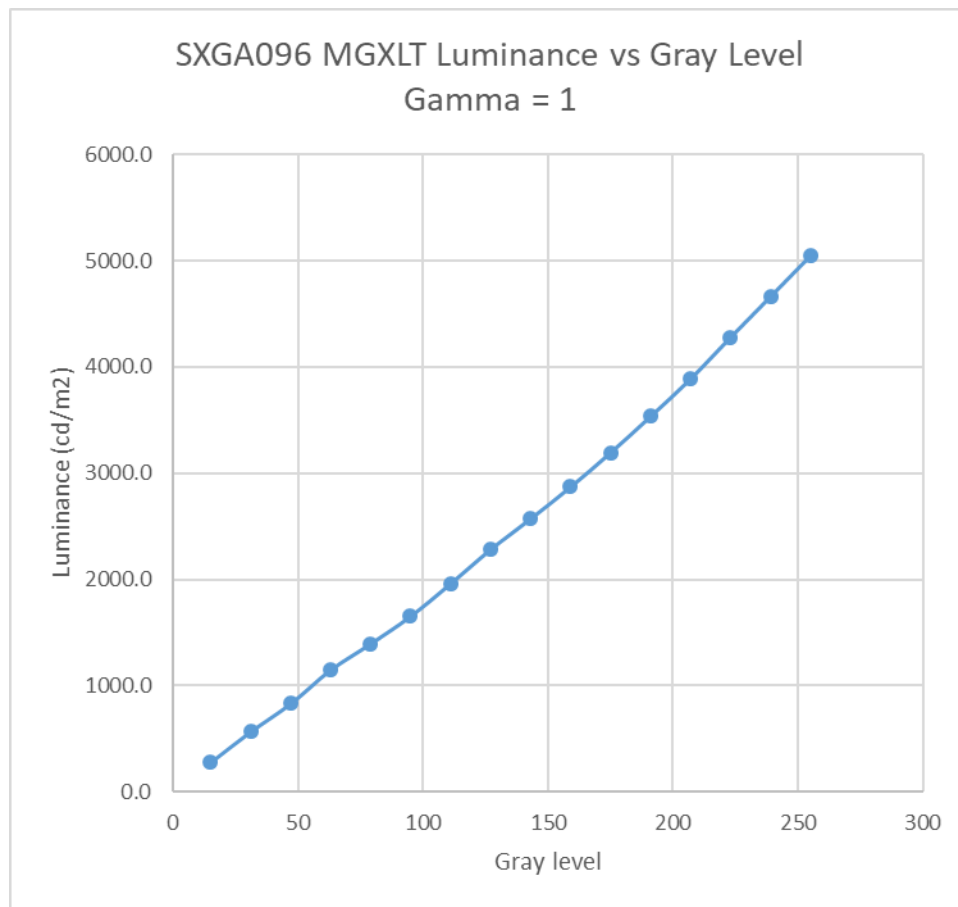

Figure 28: Typical Luminance Gamma Response

An arbitrary optical response function for the microdisplay can be obtained by performing an additional operation on the gamma coefficients before generating the gamma correction curve as described previously. For example, the relationship between the output luminance of the display (y) and the gray level input to the LUT (x) can be defined in terms of the system gamma (γ) by the following expression:

$$y = x^\gamma$$

The corresponding gamma coefficients are then given by the following expression:

$$GC_i^\gamma = \left(\frac{VGN_i}{VGN_{MAX}} * CF_i \right)^\gamma * 1023$$

For the case of a linear optical response ($\gamma=1$) this expression reduces to the simpler form given previously. Examples of gamma curves generated from the same VGN values for different settings of the System Gamma parameter are shown in Figure 29 and the corresponding system response curves for the display are given in Figure 30.

The System Gamma function is implemented in DRK Firmware and is accessible to the user in the DRK GUI Software.

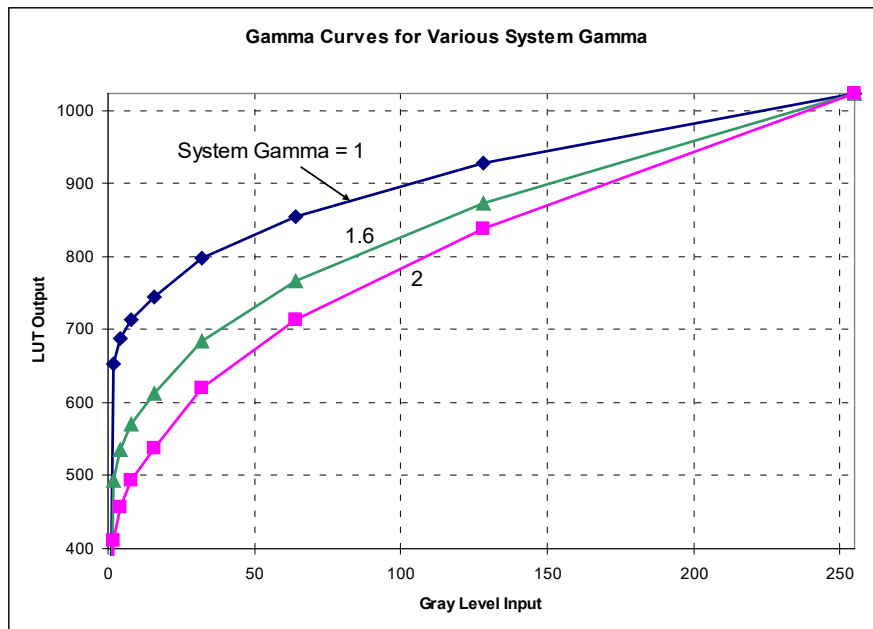

Figure 29 : Gamma curves for arbitrary System Gamma

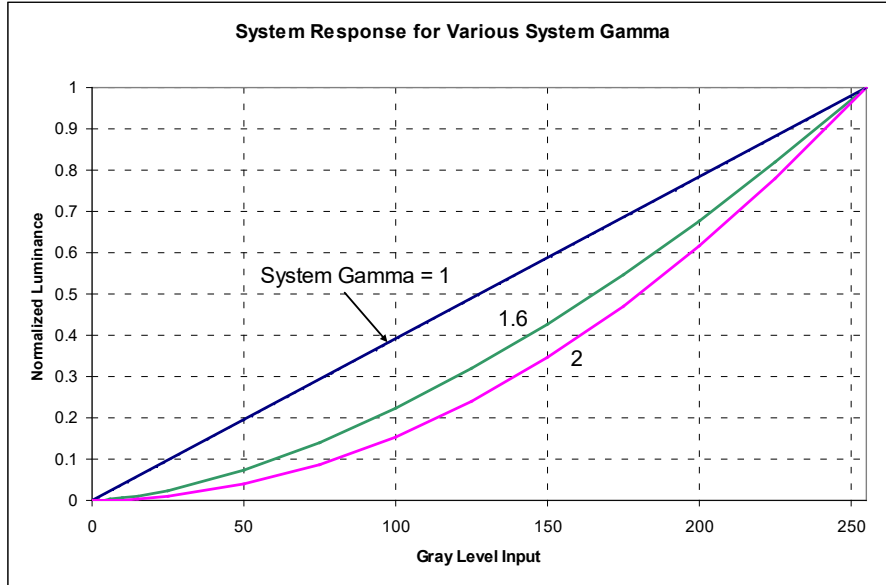

Figure 30 : Display system response for arbitrary system gamma

9.5 DC-DC Converter

An on-chip dc to dc converter controller allows for the generation of the OLED cathode supply, relying on a few external passive components assembled on the display carrier board. The converter is an adjustable inverter that converts VDD5 to a negative supply used to bias the OLED via the VCOM input pin. Adjustment is managed by the control logic and registers VCOM[7,0], VCOMCTL[7,0] and VCOMMODE[3,0].

The converter adjustment comes from two sources:

- A nominal value set in a dedicated register that provides for the room temperature voltage level.
- The output of an internal VCOM sensor circuit. This feature can be enabled/disabled via register setting to allow full external control (via register VCOM).

A block level schematic of the Cuk converter that is employed in the SXGA-096 application is shown in Figure 31.

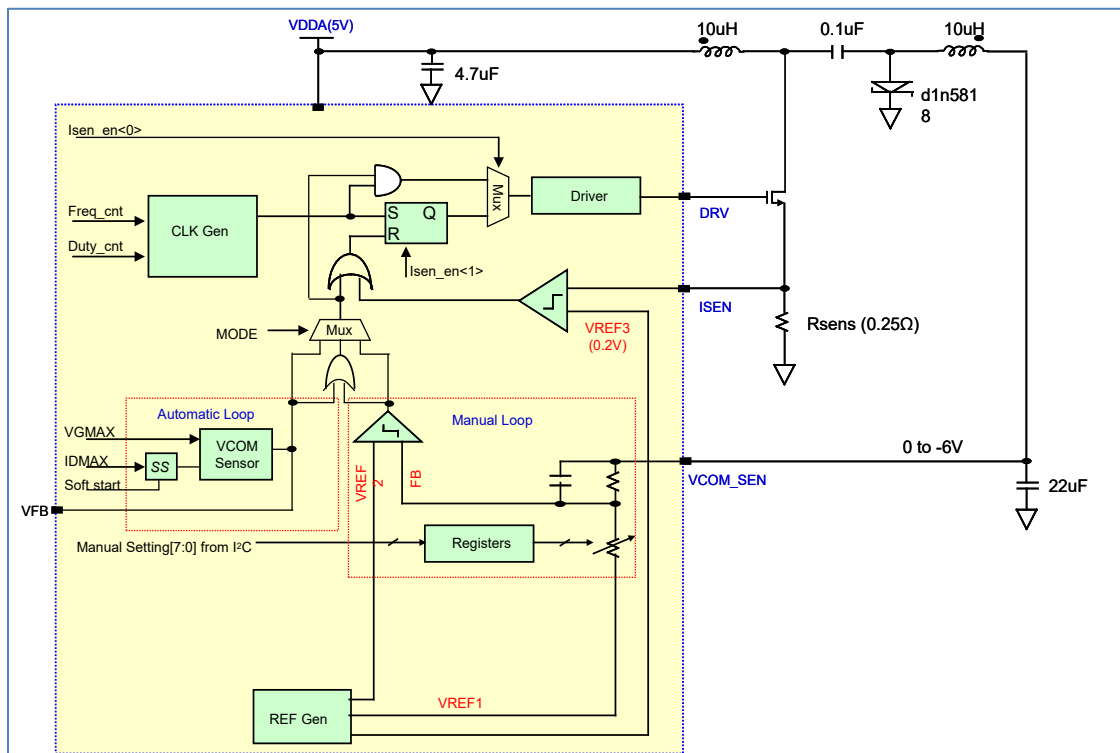

Figure 31 : Schematic of DC-DC controller function

Three modes of operation, selected via register VCOMMODE, are provided for the controller function. Mode 1, selected by default (VCOMMODE=0), activates the Automatic Loop which provides VCOM regulation based on an internal current feedback sensor. In this mode the cathode supply is automatically regulated in order to maintain a constant OLED array current over changes in temperature and luminance.

The cathode voltage will tend to rise in absolute value as the luminance level is increased or the operating temperature is reduced.

Mode 2, selected by setting $VCOMMODE=1h$, is a hybrid control mode that prevents the absolute value of the cathode supply from becoming too small at higher temperatures, but allows it to increase at low temperatures where it is needed to ensure a stable regulated OLED current. Both the AUTO and MANUAL control loops are running simultaneously in this mode with one taking charge above a user defined threshold (set by register VCOM) and the other below that threshold. For relatively low temperatures and high luminance levels the AUTO mode will be in control and the cathode supply will follow the trajectory shown in Figure 32. If operating conditions try to force the absolute value of the cathode supply to drop below the threshold, then the control switches to MANUAL mode and the regulated supply remains fixed at the VCOM level.

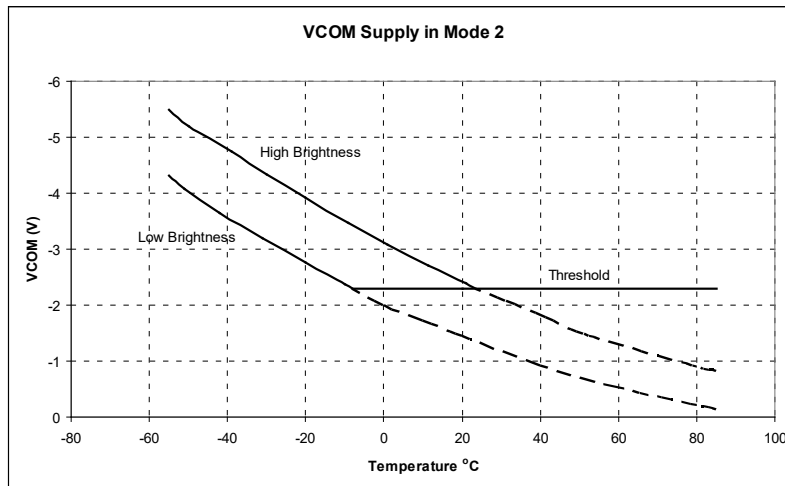

Figure 32 : VCOM supply characteristic in Mode 2

Mode 3, selected by setting $VCOMMODE=2h$, activates the Manual Loop which provides a fixed cathode supply based on a cathode voltage feedback signal. The actual value of the cathode voltage is controlled over a range of 0 to -6V by setting register VCOM. Its default value is about -2.3V. In this mode the dimming and luminance regulation functions via IDRF and DIMCTL are not operational. Luminance is controlled directly via the VCOM register setting in this mode instead.

Note: eMagin recommends using Mode 1 for typical applications.

9.6 Serial Interface

The serial interface consists of a serial controller and registers. The serial controller follows the I2C protocol. An internal address decoder transfers the content of the data into appropriate registers. The protocol will follow the address byte followed by register address data byte and register data byte sequence (3 bytes for each register access):

- Serial address with write command
- Register address
- Register data

The registers are designed to be read/write. Read mode is accomplished via a 4 byte sequence:

- Serial address with write command
- Register address
- Serial address with read command
- Register data

RANDOM REGISTER WRITE PROCEDURE

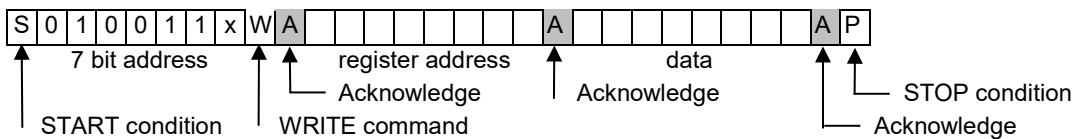

RANDOM REGISTER READ PROCEDURE

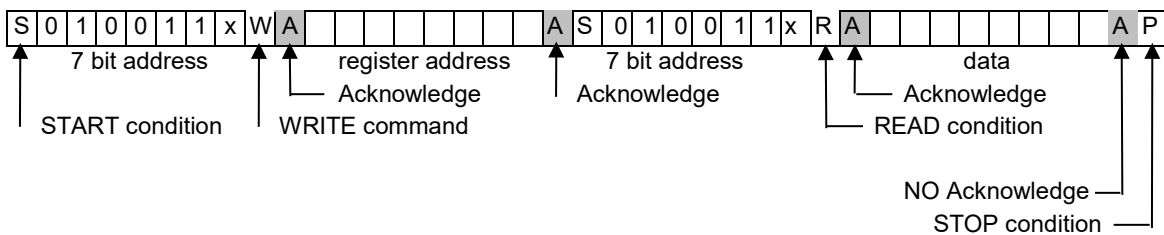

The serial controller is capable of slave mode only.

The x in the 7-bit address code is set by the SERADD input pin and is provided to allow a dual display and single controller configuration.

Slave Address: 010011X where X = 0 or 1 depending on the status of the SERADD pin. This is summarized in Table 9-6.

Write Mode: Address is 4C (or 4E if SERADD = 1)

Read Mode: Address is 4D (or 4F if SERADD = 1)

Sequential Read/Write Operation

The serial controller allows for both sequential and read operational modes. For either mode, the host needs only set the initial register address followed by as many data bytes as needed, taking care not to issue a STOP condition until all desired data bytes have been transmitted (or received).

It is possible to run the I²C interface without source clock or any sync signals.

Interface maximum frequency: 400 KHz.

Table 9-6: I2C Address Summary

	BIT 7	BIT 6	BIT 5	BIT 4	BIT 3	BIT 2	BIT 1	BIT 0	Address (Hex)
							SA	R/W	
Write	0	1	0	0	1	1	0	0	4C
Read	0	1	0	0	1	1	0	1	4D
Write	0	1	0	0	1	1	1	0	4E
Read	0	1	0	0	1	1	1	1	4F

9.7 Power-On Sequence

To ensure proper startup and stabilization of the display the following power-on sequence is recommended:

1. Turn on VDD1.8, VDD5 and VPG supplies (VDD1.8 should come up first, VDD5 about 3-5 ms after VDD1.8 has reached 90% of its final value. VPG can be powered at the same time as VDD5)
2. A ramp-up time of 0.2 to 20ms for VDD5 and VDD1.8 is recommended for best performance
3. The ramp-up time for VPG is not critical and it can be turned on anytime
4. Configure the display registers to the desired startup state
5. Turn on the display by setting the DISPOFF bit in register DISPMODE to “0”

Figure 33 shows the timing diagram for the power supplies and control signals during startup when the display is first turned on. The external supply voltages (VDD5, VDD1.8, and VPG) can all be applied as shown in the diagram. An internal power-on-reset signal is triggered when both the VDD5 and VDD1.8 voltages exceed a built-in threshold level. After a delay of about 70ms the internal dc-dc controller is activated which generates a negative supply for the common cathode of the array. The video display is enabled 20ms later and video is displayed on the array after the DISPOFF bit has been set to “0” via the serial port. Prior to this moment the pixels in the array are actively driven to the black state. The pin RESETB must also be logic high before any registers can be written.

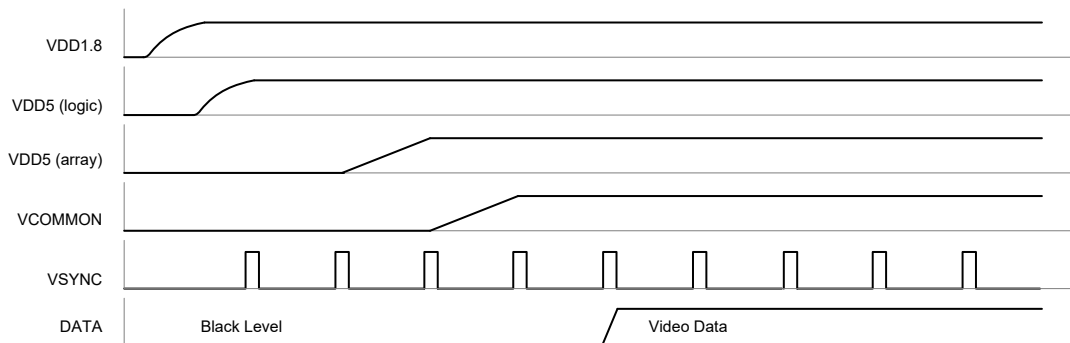

Figure 33 : Power-Up sequence for supplies and control.

During the power down operation, the supply rails should be switched off in the reverse order to the power up sequence. When the POR function detects a drop in the VDD1.8 supply below a minimum operating threshold it will immediately switch off the Row and Column sequencing circuits. At the same time the VCOMMON supply will be turned off followed by the 5V array supply. The power-down sequence is illustrated in Figure 34.

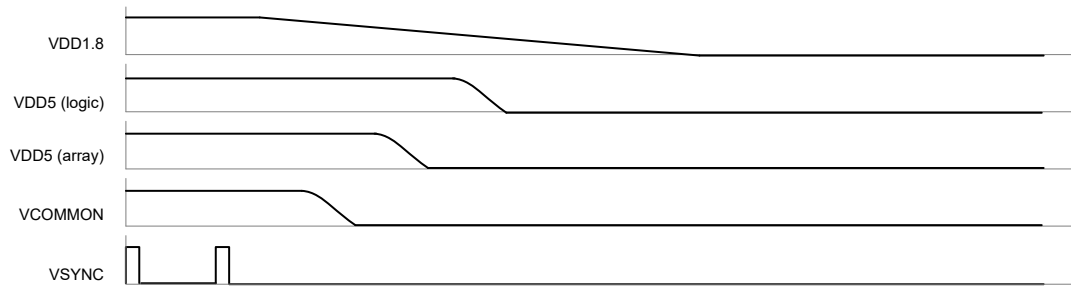

Figure 34 : Power-Down sequence for supplies and control.

9.8 Power Savings Modes

The circuit shall provide power down modes to minimize power consumption. This can occur in two ways:

- Sleep mode – manually controlled via the PDWN bit in register SYSPWRDN, the entire display chip is powered down except for the serial interface. The register settings are saved and restored on power up from this mode.
- Individual block control - many functional blocks have the option to be turned off individually via control of registers ANGPWRDN and SYSPWRDN.

9.9 Built-In Test Patterns

The IC includes functionality to simplify the external hardware requirements for test of OLED microdisplays and applications. The display is self-powered for this mode with no external video, sync, or clock signals required. The display starts in this mode with a simple, flat white field at maximum luminance by default and without the need for register setting.

The BI mode is activated at start-up when a dedicated pin TMODE is set to logic level 1 or PATTEN bit in register TPMODE is set high. The internal dc-dc converter oscillator is used to generate the basic timing sequence (VSYNC, HSYNC, and SCLK). The vertical frequency will be set to 60Hz.

By default an all-pixels-on pattern will be displayed. The following extra test patterns are included and are accessed via the serial interface:

- 16 level gray scale, checkerboard, alternating rows and columns, cross-hatch line pattern

Figure 35 illustrates the application setup for the chip in BI mode using the built-in test functionality.

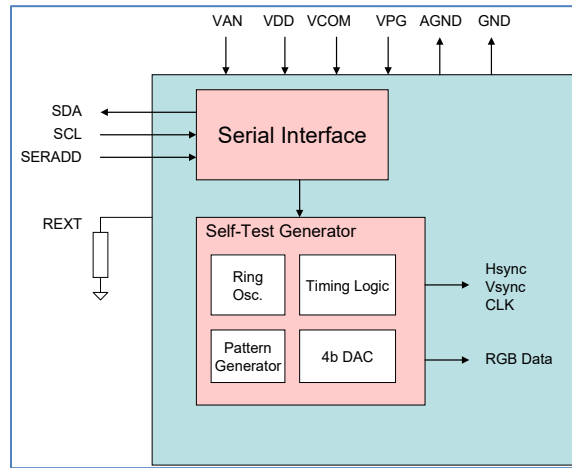

Figure 35 : Block diagram of setup for BI mode

10. REGISTER MAP SUMMARY

I2C Slave Address : 0100 11x						
Address (Hex)	Name	Access	Bit Name	Bit #	Reset Value (Hex)	Description
00	STAT	R	REV	2-0	0	Silicon Revision Number
01	VINMODE	R/W	WRDISABLE	7	0	I ² C Register Write Disable 0 = Write Enable, 1 = Write Protected (Read Only)
			Reserved	6	0	Do Not Change
			DVGA	5	0	DVGA video input mode enable 0 = SXGA video mode, 1 = DVGA video mode
			SET_ENABLE	4	0	ENABLE Active Level 0 = ENABLE active low, 1 = ENABLE active high
			SET_FIELD	3	0	FIELD Polarity 0 = Odd Field when ENABLE=Active, 1 = Even Field when ENABLE=Active
			AUTOSYNC	2	1	Auto HSYNC/VSNC polarity detection enable (Detected polarity override VSINCPOL/HSINCPOL) 0 = Disable, 1 = Enable
			VSINCPOL	1	1	VSNC Polarity 0 = Negative Sync, 1 = Positive Sync
02	DISPMODE	R/W	HSINCPOL	0	1	HSYNC Polarity 0 = Negative Sync, 1 = Positive Sync
			DISPOFF	7	1	Display Off (BURNIN mode override to ON) 0 = Display On, 1 = Display Off
			MONO	6	0	Mono display mode 0 = Color display mode, 1 = Mono display mode (Green video input data used as mono video)
			GAMMA_EN	5	1	Internal Gamma LUT Enable (BURNIN mode override to Bypass Internal Gamma) 0 = Bypass Internal Gamma LUT, 1 = use Internal Gamma LUT
			3D-MODE	4	0	3D Display Mode 0 = Normal Display, 1 = Time Sequential Mode
			SCMODE	3-2	0	Progressive or Interlaced scan mode select 00 = Progressive, 01 = Interlaced, 1X = Pseudo Interlaced
			VSCAN	1	0	Vertical Scan Direction 0 = Top to Bottom Scan, 1 = Bottom to Top Scan
03	LFTPOS	R/W		7-0	06	Column Display Left Position
05	TOPPOS	R/W		7-0	06	Row Display Top Position
06	BOTPOS	R/W		7-0	06	Row Display Bottom Position
07-08	ROWRESET	R/W		7-0	0	Row Duty Control
				9-8		0:Disable, Each line displayed ROWRESET*2 Line period
				12	0	ROWRESET work on UNENABLED frame in 3D mode
09	RAMPCTL	R/W	RAMPMON	5	0	Internal Ramp Buffer Monitor Enable
			Reserved	4	0	Do Not Change
			RAMPHIGH	3	0	Internal Ramp DAC set All High 0 = Normal operation, 1 = DAC set All High
			FLYBTIME	2	0	Ramp Fly back Time 0 = 800 nSec, 1 = 500 nSec
			RAMPDLY	1-0	1	Ramp Delay by DCLK 00 = -1/2 DCLK, 01 = No Delay, 10 = +1/2 DCLK
			RAMPBCM	7-4	4	Ramp Buffer Current Control (0000 = -75%(Don't use), 0001 = -75%, 0010 = -50%, 0111 = -25%, 0100 = ±0%, 0101 = +25%, 0110 = +50%, 0111 = +75%,...), 25% increase for each step
			RAMPACM	3-0	4	Ramp Amp Current Control (0000 = -75%(Don't use), 0001 = -75%, 0010 = -50%, 0111 = -25%, 0100 = ±0%, 0101 = +25%, 0110 = +50%, 0111 = +75%,...), 25% increase for each step
0B	VDACMX	R/W		7-0	80	Ramp DAC Max Value Control, -40% ~ +40 %
0C	BIASN	R/W	EXT_VREF	3	0	External VREF Enable 000 = bias current off
			BIASN	2-0	1	001~111 = bias current set to 0.5nA, 1nA, 1.5nA, 2nA, 2.5nA, 3.0 nA, 3.5 nA
0D	GAMMASET	R/W	PMPHOLD_EN	4	0	VCOM PUMP hold enable when VGN sampling time 0 = Normal pumping, 1 = Pump hold function enable
			VGN SH EN	3	0	VGN Sample & Hold Enable 0 = VGN SH Bypass, 1 = Enable VGN SH output
			IDSTEP	2-0	0	Current level for gamma sensor
0E	VCOMMODE	R/W	ISEN_EN	3-2	1	VCOM I-Sensor Enable
			VCOMAUTO	1-0	0	00 = AUTO1 mode 01 = AUTO2 mode 10 = MANUAL mode

0F	VCOMCTL	R/W	SS_BYPASS	7	0	VCOM Soft Start Bypass mode 0 = Soft Start function enable, 1 = Soft Start Bypass
			VCKDUTY	6-4	3	VCOM Clock Duty Control (High:Low) 0=1:7, 1=1:3, 2=3:5, 3=1:1, 4=5:3, 5=3:1, 6=7:1, 7=Don't use
			VCKSEL	3-2	3	VCOM Clock Select 0=125KHz, 1=250KHz, 2=500KHz, 3=800KHz
			VCOMSS	1-0	1	VCOM Soft Start Delay Time Mode 0 = 2mS, 1 = 4mS, 2 = 8mS, 3 = 16mS
10	VGMAX	R/W		7-0	0D	Fine adjustment for VGMAX level (default = 4.95V)
11	VCOM	R/W		7-0	51	VCOM manual setting (used when VCOMMODE = 01 or 10, default = -2.3V)
12	IDRF	R/W	IDRF_COARSE	7-5	0	Coarse adjustment for array reference current
			IDRF_FINE	4-0	0	Fine adjustment for array reference current
13	DIMCTL	R/W		6-0	01	Dimming level control (default = 1X IDRF)
14	TREFDIV	R/W		5-0	17	Temp. Sensor Reference Clock Divider
15	TEMPOFF	R/W		7-0	3A	Temp. Sensor Offset
16	TUPDATE	R/W		7-0	FF	Number of frames per TEMPOUT update (Data range 02H ~ FFH) Update Time = (TUPDATE+1) * PERIOD _{FRAME} PERIOD _{FRAME} = 16.6 mSec when using 60Hz Video
17	TEMPOUT	RO		7-0	-	Temperature Sensor Readout
18	ANGPWRDN	R/W	ISENPD	7	0	ISEN Power Down
			IDMAXPD	6	0	IDMAX Power Down
			VCOMP	5	0	VCOM Power Down
			VREFPD	4	0	VREF Power Down
			GMSENPD	3	0	Gamma Sensor Power Down
			VCMSENPD	2	0	VCOM Sensor Power Down
			TSENPD	1	0	Temperature Sensor Power Down
			TREFPD	0	0	Temperature Reference Power Down
19	SYSPWRDN	R/W	PDWN	7	0	All System Power Down (Override all analog power down, except LDOPD, POR50VDP, POR25VDP)
			LVDSPD	6	0	LVDS receiver Power Down
			LDOPD	5	0	1.8V LDO Power Down
			RBUFDP	4	0	RAMP Buffer Power Down
			RAMPDP	3	0	RAMP DAC AMP Power Down
			DACPD	2	0	RAMP DAC Power Down
			POR50VDP	1	0	5V POR Power Down
			POR18VDP	0	0	1.8V POR Power Down
1A	TPMODE	R/W	TPVCLK	4	0	Enable external clock for Burn-in test mode (0=use internal ring OSC, 1=use external LVDS clock)
			PATTEN	3	0	Test Pattern Display Enable when "1"
			PATTSEL	2-0	0	Select test pattern for Built In Test Mode (BURNIN pin = 'High' or PATTEN = 1) 000= Burn-in (all white), 001=Color Bar, 010=16 level gray scale 011=Checker Board, 100=Vertical Line, 101=Horizontal Line, 110=Gnd Pattern, 111=Color Screen
1B	TPLINWTH	R/W		7-0	0	Line Test Pattern Line Width (0=1pixel, 1=2pixel, ..., 255=256pixel)
1C	TPCOLSP	R/W		7-0	0	Line Test Pattern Column Space (0=1pixel, 1=2pixel, ..., 255=256pixel)
1D	TPROWSP	R/W		7-0	0	Line Test Pattern Row Spce (0=1pixel, 1=2pixel, ..., 255=256pixel)
1E	TPCOLOR	R/W		7-0	7	When PATTSEL=1,2 :Bit7-Bit0 :Don't care When PATTSEL=3,4,5,6 :Bit6-Bit4 :Line Test Pattern Background Color (RGB) Bit2-Bit0 :Line Test Pattern Background Color (RGB) When PATTSEL=7, All 8 bits used 256 gray level
1F	DLYSEL	R/W	SKWDLY	7-4	0	Select LVDS Skew Align reference Clock delay 0 = no delay, 1 = one unit delay, ..., 15 = 15 unit delay
			CLKDLY	3-0	1	Select clock delay for serial data latch 0 = no delay, 1 = one unit delay, ..., 15 = 15 unit delay
20	LVDSCTL	R/W	ALNMOD	2	0	LVDS Align mode 0 = normal Operation, 1 = auto align mode
			SKEWMOD	1-0	0	LVDS Skew mode 0 = normal Operation, 1 = auto skew, 2 = manual skew one set for all (use SKEW0), 3 = manual skew separate setting
21	SKEW0	R/W		7-0	0	LVDS data line #0 skew setting (when SKEWMOD=2, SKEW0 override others) 0000h = no delay, 0001 = 1 unit delay, ..., FFFFh = 15 unit delay
22				15-8		
23	SKEW1	R/W		7-0	0	LVDS data line #1 skew setting 0000h = no delay, 0001 = 1 unit delay, ..., FFFFh = 15 unit delay
24				15-8		
25	SKEW2	R/W		7-0	0	LVDS data line #2 skew setting 0000h = no delay, 0001 = 1 unit delay, ..., FFFFh = 15 unit delay
26				15-8		
27	SKEW3	R/W		7-0	0	LVDS data line #3 skew setting 0000h = no delay, 0001 = 1 unit delay, ..., FFFFh = 15 unit delay
28				15-8		
29	SKFAST	R	SKFAST	3-0	-	MSB of SKEW3-SKEW0 read out All "0" = OK, Not all "0" = Error (need increase SKWDLY)
2A	SKSLOW	R	SKSLOW	3-0	-	LSB of SKEW3-SKEW0 read out All "1" = OK, Not all "1" = Error (need decrease SKWDLY)
2B	SYNCMOD	R/W	DEFEN	2-1	1	define ENABLE/VS pin function 00=not used (all embedded), 01=used as ENABLE, 10=used as VSYNC
			DEFHS	0	0	define HS/ALIGN pin function 0 = use as ALIGN function only, 1 = used as HSYNC and ALIGN function

2C	LUT_ADDR	R/W		7-0	0	Gamma Look-Up Table template access Address
2D	LUT_DATA	R/W	LUT_DATAH	7-0	0	Gamma Look-Up Table template R/W Data LSB (Auto LUT_ADDR increase)
2E			LUT_DATAH	9-8	0	Gamma Look-Up Table template R/W Data MSB
2F	LUT_UPDATE	R/W	UDGAMMA	3	0	Update LUT template ro R,G,B Gamma LUT enable (Auto cleared after update)
			UDRGB	2-0	7	Select R,G,B Gamma LUT to update (ex. 100=R Gamma Update)
30	Reserved	R		7-0	-	Test Purpose
31				10-8		
32	Reserved	R		7-0	-	Test Purpose
33				10-8		
34	Reserved	R/W		7-0	99	Do Not Change
35	Reserved	R/W		7-0	99	Do Not Change
36	Reserved	R/W		3-0	0	Do Not Change
37	Reserved	R/W		6-0	0	Do Not Change
38	Reserved	R/W		7-0	0	Do Not Change
39	Reserved	R/W		7-0	0	Do Not Change
3A	Reserved	R/W		7-0	FF	Do Not Change
3B	Reserved	R/W		7-0	0	Do Not Change
3C	Reserved	R/W		4-0	0	Do Not Change
3D	Reserved	R/W		2-0	3	Do Not Change
40	Reserved	R/W		6-0	0	Do Not Change
41	Reserved	R/W		7-0	30	Do Not Change
42	Reserved	R/W		6-0	64	Do Not Change

11. DETAILED REGISTER DESCRIPTIONS

11.1 STAT (00h)

Name	STAT
Address	00h
Mode	Read Only

Bit Name	Bit#	Reset Value	Description
REV	2-0	0	Silicon revision number; Rev. 1 = 0

Bits REV in this register indicate the revision number of the silicon backplane design, with 0 corresponding to the first silicon known as Rev. 1.

11.2 VINMODE (01h)

Name	VINMODE
Address	01h
Mode	Read / Write

Bit Name	Bit#	Reset Value	Description
WRDISABLE	7	0	I ² C register write disable
Reserved	6	0	Do Not Change
DVGA	5	0	VGA Video Input Mode Enable
SET_ENABLE	4	0	ENABLE active level
SET_FIELD	3	0	Field polarity
AUTOSYNC	2	1	Automatic VSYNC/HSYNC Polarity Detection Enable
VSYNCPOL	1	1	VSYNC polarity
HYSYNCPOL	0	1	HSYNC polarity

WRDISABLE:

- 1 = write protected (all other registers become read only)
- 0 = write enable (all registers can be updated externally via I²C) (default)

DVGA:

- 0 = SXGA video mode (default)
- 1 = Double VGA video mode

When the video source is the VGA resolution, the SXGA-096 makes the pixel data double internally and display it in 1280 x 960 pixel area with this register enable.

SET_ENABLE:

- 0 = the active state of the ENABLE input is set "low" (default)
- 1 = the active state of the ENABLE input is set "high"

The ENABLE input pin is used to implement 3D video modes using a single RGB source, with two consecutive frames carrying information for each eye. The microdisplay can be programmed for either an active high or low ENABLE input using the SET_ENABLE bit, allowing a single video signal to be used with two displays. In such a configuration, one display scans and displays, while the other one holds and displays. The active state of the ENABLE input corresponds to the video data being scanned and displayed by the microdisplay.

To implement the Frame Sequential 3D Mode according to the VESA Standard for Stereoscopic Display Hardware, the display for the left eye is programmed with SET_ENABLE=1 and the right eye display is programmed with SET_ENABLE=0. Consequently, the data for the left eye is supplied and displayed when ENABLE=1 while the display for the right eye displays the previous frame of data.

The ENABLE input pin is also used to indicate field polarity in non-3D interlaced modes. In this mode the SET_FIELD bit determines the field polarity when ENABLE is active.

SET_FIELD:

- 0 = Odd Field when ENABLE=Active (default)
- 1 = Even Field when ENABLE=Active

The SET_FIELD register determines the field polarity of the video signal when the ENABLE pin is active.

AUTOSYNC:

- 0 = Auto Sync detection mode OFF
- 1 = Auto Sync detection mode ON (default)

VSYNCPOL and HSYNCPOL are overridden by detected sync polarity when AUTOSUNC = 1.

VSYNCPOL:

- 0 = Negative Sync (default)
- 1 = Positive Sync

HSYNCPOL:

- 0 = Negative Sync (default)
- 1 = Positive Sync

The SYNCPOL registers are used to determine whether the positive or negative edge of the external synchronization clocks (HSYNC and VSYNC) is used as the active transition by the internal display sequencers and control logic.

11.3 DISPMODE (02h)

Name	DISPMODE
Address	02h
Mode	Read / Write

Bit Name	Bit#	Reset Value	Description
DISPOFF	7	1	Display On/Off control
MONO	6	0	Mono display mode selection
GAMMA_EN	5	1	Internal Gama LUT enable
3D-MODE	4	0	3D Mode control
SCMODE	3-2	0	Progressive or Interlaced scan mode selection
VSCAN	1	0	Vertical Scan direction
HSCAN	0	0	Horizontal Scan direction

DISPOFF:

- 0 = Display is turned ON
- 1 = Display is turned OFF (default)

The display starts in the OFF state by default and requires a command via the serial port to be turned on.

MONO:

- 0 = Monochrome white display mode (default)
- 1 = Mono display mode

The MONO is used to set monochrome display mode. When MONO = 1, the SXGA-096 only accept the input data from LVDS channel 1 and 2. Other channels (channel 0, 3) go to power down mode.

GAMMA_EN:

- 0 = Bypass Internal Gamma LUT
- 1 = Use internal Gamma LUT

3D-MODE:

- 0 = Normal display mode (default)
- 1 = Time Sequential 3D mode

This bit is used to set the 3D mode of operation in conjunction with SET_ENABLE (bit #3 of the VINMODE register) and the Enable input. In Frame Sequential Mode each video frame contains information for either the left or right eye. When 3D-MODE="1" the SCMODE bit in the DISPMODE register is overridden to Progressive Scan Mode (0h). The following description for Frame Sequential operation assumes the source is in compliance with the VESA standard, where the data for the left eye is provided while the Enable signal is at the logic high level, and the data for the right eye display is provided while the Enable signal is at the logic low level. The Enable input signal is sampled into the circuit by a flip-flop clocked on the falling edge of VSYNC and the sampled value is used for the next

frame. (The Enable signal is generated by the graphics software and may not be synchronized to the VSYNC signal).

To activate the stereovision mode, the right eye display needs to be configured with Enable active low (SET_ENABLE= "0", bit #3 of the VINMODE register). This will allow the right eye microdisplay to hold the previous frame while the Enable input is high. The left eye display needs to be configured with Enable active high (SET_ENABLE="1", bit #3 of the VINMODE register). Thus the two Enable inputs can be tied together to the incoming Stereo Sync signal provided by the graphics adapter (or other custom source).

SCMODE:

- 00 = Progressive scan mode (default)
- 01 = Interlaced scan mode
- 1X = Pseudo-interlaced mode

Interlaced modes are limited to a maximum of 512 and a minimum of 240 active rows per field.

VSCAN:

- 0 = Top to Bottom vertical scan direction (default)
- 1 = Bottom to Top vertical scan direction

HSCAN:

- 0 = Left to Right horizontal scan direction (default)
- 1 = Right to Left horizontal scan direction

11.4 LFTPOS (03h)

Name	LFTPOS
Address	03h
Mode	Read / Write

Bit Name	Bit#	Reset Value	Description
	7-0	06	Left position of first active column

This register, along with register RGTPPOS, is used to set the horizontal position of the active display window within the 1292 available columns of pixels. In SXGA mode the active window can be moved by +/-6 pixels from the center (default) position. When LFTPOS is increased, register RGTPPOS must be decreased by the same value so that the sum of the two remains equal.

11.5 RGTPOS (04h)

Name	RGTPOS
Address	04h
Mode	Read / Write

Bit Name	Bit#	Reset Value	Description
	7-0	06	Right position of last active column

This register, along with register LFTPOS, is used to set the horizontal position of the active display window within the 1292 available columns of pixels. In SXGA mode the active window can be moved by +/-6 pixels from the center (default) position. When RGTPOS is increased, register LFTPOS must be decreased by the same value so that the sum of the two remains equal.

11.6 TOPPOS (05h)

Name	TOPPOS
Address	05h
Mode	Read / Write

Bit Name	Bit#	Reset Value	Description
	7-0	06	Top position of first active row

This register, along with register BOTPOS, is used to set the vertical position of the active display window within the 1036 available rows of pixels. In SXGA mode the active window can be moved by +/-6 pixels from the center (default) position. When TOPPOS is increased, register BOTPOS must be decreased by the same value so that the sum of the two remains equal.

11.7 BOTPOS (06h)

Name	BOTPOS
Address	06h
Mode	Read / Write

Bit Name	Bit#	Reset Value	Description
	7-0	06	Bottom position of last active row

This register, along with register TOPPOS, is used to set the vertical position of the active display window within the 1036 available rows of pixels. In SXGA mode the active window can be moved by +/-6 pixels from the center (default) position. When BOTPOS is increased, register TOPPOS must be decreased by the same value so that the sum of the two remains equal.

11.8 ROWRESET (07h, 08h)

Name	ROWRESET
Address	07h, 08h
Mode	Read / Write

Bit Name	Bit#	Reset Value	Description
ROWRESETL (07h)	7-0	0	Row duty rate control (LSB)
ROWRESETH (08h)	1-0	0	Row duty rate control (MSB)
	4	0	ROWRESET work on UNENABLED frame in 3D mode

ROWRESETH:BIT4

0 = Active duty rate can be set 0 ~ 50%, 100% when 3D mode

1 = Active duty rate can be set 50 ~ 100% when 3D mode

This register is used to set the number of line cycles (in steps of 2) during which each row is active in any frame period. Each row is driven to black during the non-active line cycles.

ROWRESET (dec)	Active Line Cycles	Active Duty Rate (%)	Note
0	all	100	Pixels active for entire frame period
1	2	$2 \cdot T_{HSYNC} / T_{FRAME}$	1054 total HS cycles / frame (SXGA/60Hz)
n	$2 \cdot n$	$2 \cdot n \cdot T_{HSYNC} / T_{FRAME}$	
>527	all	100	Pixels active for entire frame period

11.9 RAMPCTL (09h)

Name	RAMPCTL
Address	09h
Mode	Read / Write

Bit Name	Bit#	Reset Value	Description
RAMPMON	5	0	Internal RAMP Amp monitor enable
	4	0	Reserved (Do Not Change)
RAMPHIGH	3	0	Set internal RAMP DAC high
FLYBTIME	2	0	RAMP Flyback time
RAMPDLY	1-0	1	RAMP delay in DCLK cycles

RAMPMON:

0 = Disable internal RAMP Buffer monitoring (default)

1 = Enable internal RAMP Buffer monitoring

The RAMPMON register is used to enable monitoring of the internal RAMP buffer output signal.

RAMPHIGH:

0 = Normal operation (default)
1 = DAC set to all high output

The RAMPHIGH register is used to set internal RAMPDAC to all high output mode for test purposes.

FLYBTIME:

0 = 500 ns (default)
1 = 800 ns

The FLYBTIME register is used to set the fly-back (return to 0) time for the internal RAMP.

RAMPDLY:

00 = - ½ DLCK
01 = no delay (default)
10 = + ½ DCLK

The RAMPDLY2 register is used to adjust the starting position of the internal RAMP.

11.10 RAMPCM (0Ah)

Name	RAMPCM
Address	0Ah
Mode	Read / Write

Bit Name	Bit#	Reset Value	Description
RAMPBCM	7-4	4	RAMP Buffer current control
RAMPACM	3-0	4	RAMP Amp current control

RAMPBCM:

0000 = -100% (power down)
0001 = -75%
0010 = -50%
0011 = -25%
0100 = nominal (default)
0101 = +25%
0110 = +50%
0111 = +75%
...

The RAMPBCM register is used to set the operating bias current for the internal RAMP buffer. The settings reduce or increase the current by 25 % of the nominal (default) value.

RAMPACM:

- 0000 = -100% (power down)
- 0001 = -75%
- 0010 = -50%
- 0011 = -25%
- 0100 = nominal (default)
- 0101 = +25%
- 0110 = +50%
- 0111 = +75%
-

The RAMPACM register is used to set the operating bias current for the internal RAMP amplifier. The settings reduce or increase the current by 25% percentage of the nominal (default) value.

11.11 VDACMX (0Bh)

Name	VDACMX
Address	0Bh
Mode	Read / Write

Bit Name	Bit#	Reset Value	Description
	7-0	80	RAMP DAC maximum value control

Register VDACMX is used to adjust the maximum value of the internal RAMP DAC signal by -40% to +40% of the nominal value.

NOTE: The normal operating value for VDACMX should be set to 80h.

The typical dependence of display luminance on VDACMX(dec) is shown in Figure 36. The luminance is seen to saturate for VDACMX greater than about 7Ah in this sample. For normal operation VDACMX should be set to about 90 to 95% of the saturation value as shown in the figure.

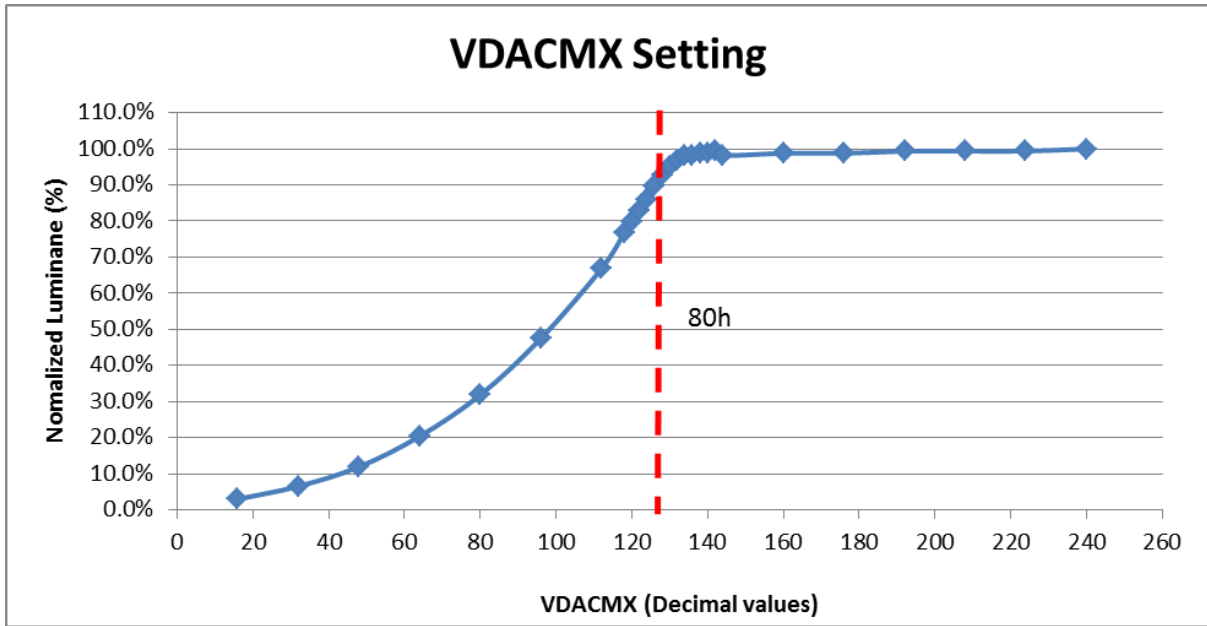

Figure 36: Luminance dependency on VDACMX

11.12 BIASN (0Ch)

Name	BIASN
Address	0Ch
Mode	Read / Write

Bit Name	Bit#	Reset Value	Description
EXT_VREF	3	0	Enable external VREF
BIASN	2-0	1	Set pixel bias current

EXT_VREF:

- 1 = enable the external VREF source
- 0 = use the internal VREF source (default)

Note: This option not available on the current package – use the default setting only.

BIASN:

- 000 = pixel bias current is turned off
- 111 = pixel bias current set to maximum

The BIASN register is used to set the sink current applied in each pixel cell. It is recommended to use the BIASN=03 setting in normal operation.

11.13 GAMMASET (0Dh)

Name	GAMMASET
Address	0Dh
Mode	Read / Write

Bit Name	Bit#	Reset Value	Description
PMPHOLD_EN	4	0	VCOM pump hold enable
VGNSH_EN	3	0	VGN sample & hold enable
IDSTEP	2-0	0	Current level for gamma sensor

PMPHOLD_EN:

- 0 = Normal operation, pump hold disabled (default)
- 1 = Enable pump hold during VGN sampling time

The PMPHOLD_EN register is used to disable the VCOM converter switch during the VGN sampling time to reduce noise pickup.

VGNSH_EN:

- 0 = Bypass the VGN sample & hold function (default)
- 1 = Enable the VGN sample & hold function

The VGNSH_EN register is used to activate the internal sample & hold function provided at the VGN output pin.

IDSTEP:

- 0h ≈ IDRF/128
- 1h ≈ IDRF/64
- 2h ≈ IDRF/32
- 3h ≈ IDRF/16
- 4h ≈ IDRF/8
- 5h ≈ IDRF/4
- 6h ≈ IDRF/2
- 7h = IDRF

The IDSTEP register is used to set the current level for the gamma sensor. The corresponding output voltage is provided at pin VGN.

A minimum of 10msec following an IDSTEP register update should be allowed for the VGN signal to settle before sampling. In addition, sampling of the VGN signal should be carried out during the Frame Blanking time.

11.14 VCOMMODE (0Eh)

Name	VCOMMODE
Address	0Eh
Mode	Read / Write

Bit Name	Bit#	Reset Value	Description
ISEN_EN	3-2	1	Enable the VCOM current sensor
VCOMAUTO	1-0	0	Set internal VCOM supply mode

ISEN_EN:

- 00 = Turn off VCOM current sensor
- 01/11 = Turn on VCOM current sense function

When the ISEN_EN is turned on, the internal VCOM current sense function is enabled. If it detects overcurrent in VCOM, the internal VCOM dc-dc converter stops the pumping signal(DRV) to protect external components.

VCOMAUTO:

This register sets the operating mode of the internal VCOM dc-dc converter.

00 = AUTO1 mode (default)
01 = AUTO2 mode
10 = MANUAL mode

In the AUTO1 mode, the VCOM converter uses an internal current reference to maintain a fixed OLED current level, which is defined by registers DIMCTL and IDRFB.
In the AUTO2 mode, the VCOM converter regulates the OLED current level when the VCOM supply is below a set threshold (defined by the VCOM register), and clamps the output to the threshold level when conditions call for a VCOM output above the threshold level.
In the Manual mode, the VCOM converter uses a voltage reference signal to maintain a fixed cathode supply voltage. The value of the cathode voltage is set by register VCOM.

11.15 VCOMCTL (0Fh)

Name	VCOMCTL
Address	0Fh
Mode	Read / Write

Bit Name	Bit#	Reset Value	Description
SS_BYPASS	7	0	Bypass the VCOM soft start mode
VCKDUTY	6-4	3	VCOM clock duty control
VCKSEL	3-2	3	VCOM clock select
VCOMSS	1-0	1	VCOM soft start delay time

SS_BYPASS:

0 = Normal operation, soft-start function enabled (default)
1 = Disable the VCOM soft-start function

VCKDUTY:

0h = 1:7
1h = 1:3
2h = 3:5
3h = 1:1 (default)
4h = 5:3
5h = 3:1
6h = 7:1
7h = don't use

Register VCKDUTY sets the VCOM clock duty ratio (high-low).

VCKSEL:

0h = 125 kHz
1h = 250 kHz
2h = 500 kHz

3h = 800 kHz (default)

Register VCKSEL sets the operating frequency of the VCOM clock.

VCOMSS:

0h = 2 ms
1h = 4 ms (default)
2h = 8 ms
3h = 16 ms

Register VCMOSS sets the soft-start duration during startup of the VCOM converter.

11.16 VGMAX (10h)

Name	VGMAX
Address	10h
Mode	Read / Write

Bit Name	Bit#	Reset Value	Description
	7-0	0D	Fine adjustment for VGMAX level

00h = 5 (VDD5 = 5V)
0Dh = 4.95 (default)
FFh = 4

$$\text{VGMAX level} = \text{VDD5} * (1 - 0.2 * \text{VGMAX}(\text{dec}) / 255)$$

This register sets the pixel voltage at which the maximum OLED current is regulated. It should be slightly below the VDD5 supply to prevent saturation of the video buffer amplifiers.

The recommended value for the MG XLT microdisplay is 4Dh

11.17 VCOM (11h)

Name	VCOM
Address	11h
Mode	Read / Write

Bit Name	Bit#	Reset Value	Description
	7-0	51	VCOM manual setting

Cathode supply as a function of VCOM setting:

VCOM(h)	FF	F0	E0	D0	C0	B0	A0	90	80	70	60	51*	40	30
----------------	----	----	----	----	----	----	----	----	----	----	----	------------	----	----

Voltage	-	-	-	-	-	-	-	-	-	-	-	-	-	-
	0.29	0.38	0.47	0.59	0.72	0.85	1.0	1.2	1.43	1.7	2.0	2.4	2.97	3.68

*default value

Register VCOM[7,0] sets the fixed output level for the internal VCOM inverter when VCOMMODE =01 or 10. There is no compensation for the variation in OLED behavior with temperature in this mode of operation. As a result, a setting at room temperature will not necessarily result in optimal contrast and the same luminance at other temperatures. The default setting (51h) will result in a cathode supply \approx -2.3V. The typical dependency of luminance on the VCOM setting in manual mode is given in Figure 37 for a color display (the profile is similar for the green XLT microdisplay).

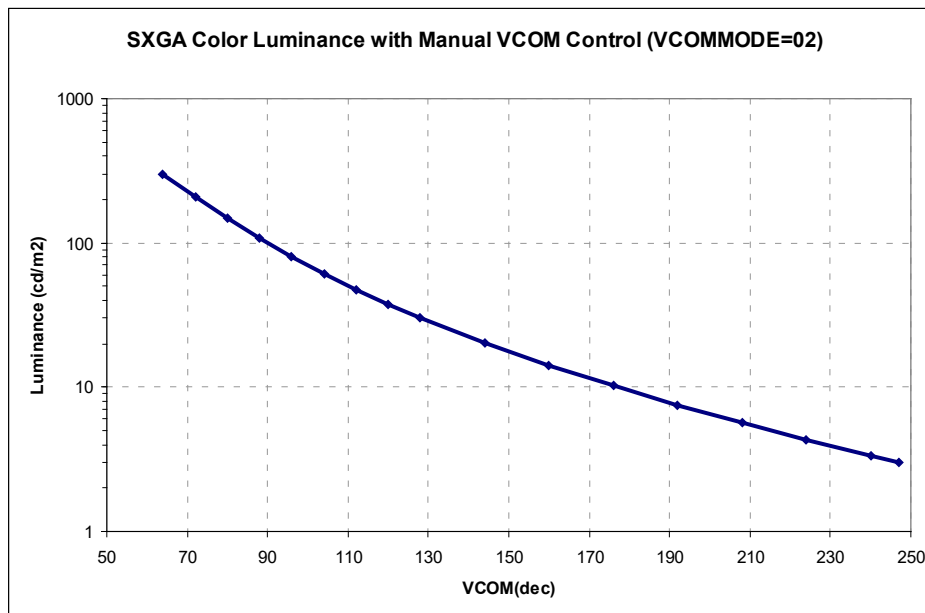

Figure 37 : Typical luminance dependency on manual VCOM setting

11.18 IDRf (12h)

Name	IDRF
Address	12h
Mode	Read / Write

Bit Name	Bit#	Reset Value	Description
IDRF_COARSE	7-5	0	Coarse adjustment for array reference current
IDRF_FINE	4-0	0	Fine adjustment for array reference current

IDRF_COARSE:

IDRF_COARSE	IC Value
000	0
001	0.5

010	1.5
011	2.5
100	3.5
101	4.5
110	5.5
111	6.5

IDRF_FINE:

IF#
00h = 0 (default)
01h = 1/32
...
10h = 16/32
...
1Fh = 31/32

Register IDRFB is used to set the maximum OLED current, which determines the luminance level for the display. The luminance will be directly proportional to the IDRFB factor (sum of IC# and IF#). The slope and origins of the Luminance vs. IDRFB are calculated at production time and saved in the on-board eeprom. Refer to section 9.4.5 for details.

11.19 DIMCTL (13h)

Name	DIMCTL
Address	13h
Mode	Read / Write

Bit Name	Bit#	Reset Value	Description
	6-0	1	Dimming level control

00h = 0
01h = 1% of LMAX
...
64h = 100% of LMAX
...
7Fh = 127% of LMAX

This register provides linear control of the display luminance level ranging from 0 to 127% in steps of 1%. The recommended value of 64h is equal to 100% of the luminance defined by register IDRFB.

This register is only operational in Auto VCOM mode (VCOMMODE=00).

11.20 TREFDIV (14h)

Name	TREFDIV
-------------	---------

Address	14h
Mode	Read / Write

Bit Name	Bit#	Reset Value	Description
	5-0	17	Temperature sensor reference clock divider adjust

The register TREFDIV is used to adjust the slope of the temperature readout sensor response, TEMPOUT, to correspond to the desired operating range of the display. The default setting is intended to support a full scale temperature range of -40 to 80°C, although the setting is best determined by a calibration measurement of the display in its final assembly.

See the description for register TEMPOUT.

11.21 TEMPOFF (15h)

Name	TEMPOFF
Address	15h
Mode	Read / Write

Bit Name	Bit#	Reset Value	Description
	7-0	3A	Temperature sensor offset adjust

The register TEMPOFF is used to adjust the offset of the temperature readout sensor response, TEMPOUT, to correspond to the desired operating range of the display. The default setting is intended to support a full scale temperature range of -40 to 80°C, although the setting is best determined by a calibration measurement of the display in its final assembly.

See the description for register TEMPOUT.

11.22 TUPDATE (16h)

Name	TUPDATE
Address	16h
Mode	Read / Write

Bit Name	Bit#	Reset Value	Description
	7-0	FF	Number of frames per TEMPOUT update

This register sets the update rate of the Temperature Sensor reading, TEMPOUT. The time between sensor updates is given by:

$$\text{Update Time} = (\text{TUPDATE}(\text{decimal}) + 1) * T_{\text{FRAME}}$$

where the frame period T_{FRAME} is equal to 16.6 ms for 60Hz video. The valid range for TUPDATE is 02h to FFh.

11.23 TEMPOUT (17h)

Name	TEMPOUT
Address	17h
Mode	Read Only

Bit Name	Bit#	Reset Value	Description
	7-0	-	Temperature sensor readout

Register TEMPOUT provides an 8bit digital output that is linearly proportional to the chip temperature. The VGA display temperature sensor is designed around a P-N junction. The output of the junction is sampled by an internal current to voltage converter, digitized and stored into a dedicated 8-bit register TEMPOUT. The sampling rate is controlled by configuration register TUPDATE (16H). By default the temperature sensor is updated once every 255 frames. Two registers are used to set the sensor gain (TREFDIV) and sensor offset (TEMPOFF). The temperature sensor can be powered down when not used by setting TSENPDP =1 in the PWRDN register.

The temperature sensor is intended to provide a full-scale reading over a temperature range defined by the user. Assuming that the desired operating temperature range is defined by T_{MIN} and T_{MAX} , the expected sensor response would be as follows:

$$TEMPOUT(dec) = A * temp + B$$

where temp is the chip temperature in degrees Celsius, and A and B are given by:

$$A = \frac{255}{T_{MAX} - T_{MIN}}$$

$$B = \frac{-255 * T_{MIN}}{T_{MAX} - T_{MIN}}$$

The actual sensor response is determined by registers TREFDIV and TEMPOFF through the following relationship:

$$TEMPOUT(d) = k_1 * TREFDIV(d) * temp + k_2 + TEMPOFF(d)$$

The constants k_1 and k_2 are dependent on properties of the silicon and package assembly. For example, the average register settings needed to achieve a working temperature range of -60°C to +80°C are given by the following values for package A04-500463-01:

$$TREFDIV(d) = 25$$

$$TEMPOFF(d) = 93$$

Using these values will result in a variation in temperature reading from part to part due to manufacturing tolerances. To get a reasonably good sensor performance it is usually enough to just find the optimum

value for TEMPOFF which requires only one measurement at room temperature. Increased accuracy can be obtained for a specific part by performing the calibration measurements described below.

To find the optimum value for TREFDIV do the following:

- Place the display in a temperature controlled environment, e.g. an oven
- Set TREFDIV=25d=19h and TEMPOFF=0
- Set DISPMODE=20h (turn off the display)
- Read TEMPOFF at several ambient temperatures, e.g. 0°C, 20°C, 40°C, 60°C
- Take the slope to find the sensor response, $A_{MEAS} = dTEMPOUT(d)/dtemp$
- The optimum value for TREFDIV is then given by

$$TREFDIV_{OPT} = 25 * \frac{1.82}{A_{MEAS}}$$

To find the optimum value for TEMPOFF do the following:

- Set TREFDIV=25d=19h (or the optimum value) and TEMPOFF=0
- Set DISPMODE=20h (turn off the display)
- Allow several minutes to stabilize and then read $TEMPOUT_{AMB}$ and the ambient temperature T_{AMB}
- The optimum value for TEMPOFF is then given by

$$TEMPOFF_{OPT} = 1.82 * T_{AMB} + 109 - TEMPOUT_{AMB}$$

With these settings, the microdisplay temperature can be found from the sensor reading through the following relationship:

$$T(^{\circ}C) = \frac{140}{255} * TEMPOUT(d) - 60$$

Temperatures below -60°C will return a TEMPOUT reading of 0 and temperatures above +80°C will return a hexadecimal value of FF.

11.24 ANGPWRDN (18h)

Name	ANGPWRDN
Address	18h
Mode	Read / Write

Bit Name	Bit#	Reset Value	Description
ISENPD	7	0	ISEN power down
IDMAXPD	6	0	IDMAX power down
VCOMPDP	5	0	VCOM power down
VREFPD	4	0	VREF power down
GMSENPD	3	0	Gamma sensor power down
VCSENPD	2	0	VCOM sensor power down
TSENPDP	1	0	Temperature sensor power down
TREFPD	0	0	Temperature reference power down

ISENPD:

1 = VCOM current limit sensor is powered down
0 = normal operation (default)

IDMAXPD:

1 = IDMAX function is powered down
0 = normal operation (default)

VCOMPDP:

1 = VCOM generator is powered down
0 = normal operation (default)

VREFPD:

1 = the VREF reference source is powered down
0 = normal operation (default)

GMSENPD:

1 = the Gamma sensor is powered down
0 = normal operation (default)

VCSNEPD:

1 = the VCOM sensor is powered down
0 = normal operation (default)

TSENPDP:

- 1 = the Temperature Sensor is powered down
- 0 = the Temperature Sensor is operating normally (default)

TREFPDP:

- 1 = the Temperature reference is powered down
- 0 = normal operation (default)

11.25 SYSPWRDN (19h)

Name	SYSPWRDN
Address	19h
Mode	Read / Write

Bit Name	Bit#	Reset Value	Description
PDWN	7	0	All systems power down
LVDSPPD	6	0	LVDS receiver power down
LDOPD	5	0	1.8V LDO power down
RBUFPD	4	0	RAMP Buffer Power Down
RAMPPD	3	0	RAMP DAC amp and buffer power down
DACPD	2	0	RAMP DAC power down
POR50VPD	1	0	5V power-on-reset power down
POR18VPD	0	0	2.5V power-on-reset power down

PDWN:

- 1 = all systems are powered down
- 0 = normal operation (default)

By setting the PDWN bit with LDOPD bit to a “1” the chip enters a deep sleep mode in which all functions including the I²C interface are powered down in order to minimize power consumption. The data, sync and clock inputs should be inactive and held low to achieve the lowest power consumption. An on-chip Address Detection circuit monitors the I²C input lines and resets the PDWN bit when it detects the correct I²C address, restoring the display to operating mode.

All register settings are saved in the power down mode and the display will restart in its previous state when normal operation is resumed.

LVDSPPD:

- 1 = LVDS receiver is powered down
- 0 = normal operation (default)

LDOPD:

- 1 = 1.8V LDO is powered down
- 0 = 1.8V LDO is enabled (default)

It is recommended not to use the internal 1.8V LDO, so the LDOPD bit should be set to “1” when power up the display.

RBUFPD:

- 1 = internal RAMP buffer is powered down
- 0 = normal operation (default)

RAMPPD:

- 1 = internal RAMP DAC amplifier is powered down
- 0 = normal operation (default)

DACPD:

- 1 = internal RAMP DAC is powered down (use when external RAMP option is enabled)
- 0 = internal RAMP DAC is operational (default)

The internal RAMP DAC generator may be power down if an external RAMP source is used.

POR50VPD:

- 1 = the 5V power-on-reset circuit is powered down
- 0 = normal operation (default)

POR18VPD:

- 1 = the 1.8V power-on-reset circuit is powered down
- 0 = normal operation (default)

11.26 TPMODE (1Ah)

Name	TPMODE
Address	1Ah
Mode	Read / Write

Bit Name	Bit#	Reset Value	Description
TPVCLK	4	0	Enable external clock in Burn-in mode
PATTEN	3	0	Enable test pattern display
PATTSEL	2-0	0	Select test pattern for Burn-In mode

TPVCLK:

- 0 = Internal ring oscillator is used for test pattern generation (default)
- 1 = Test pattern generator use the external clock which is LVDS clock

The BI pin is tied high or PATTEN register set to high to activate the Burn-In test mode which can be used to check display functionality without the presence of external video data or clock signals. In this

mode the display generates data, syncs and the pixel clock internally for several different video patterns. The TPMODE register is used to select one of the built-in test patterns in Burn-In mode via the serial interface.

- 000 = all white pattern (default)
- 001 = monochrome white bars
- 010 = gray scale (without gamma correction)
- 011 = checkerboard pattern
- 100 = alternating columns pattern
- 101 = alternating rows pattern
- 110 = grid pattern
- 101 = all black
- 111 = monochrome white screen based on TPMONOCROME WHITE register value.

Use with registers TPLINWTH, TPCOLSP, TPROWSP and TPMONOCROME WHITE to modify the patterns according to Figure 38.

Test Pattern Name	PATTSEL (1BH:2-0)	TPLINWTH (1CH)	TPCOLSP (1DH)	TPROWSP (1EH)	TPMONOCHROME WHITE (1FH)	
					(1FH:2-0)	(1FH:6-4)
All White	000	X	X	X	X	X
Monochrome white Bar	001	X	X	X	X	X
Gray Scale	010	X	X	X	X	X
Checker Board	011	X	X	X	111	000
Alternating Column	100	LW	CS	X	111	000
Alternating Row	101	LW	X	RS	111	000
Grid Pattern	110	LW	CS	RS	111	000
All Black	101	X	X	X	000	000
All White	101	X	X	X	111	111
All Red	101	X	X	X	100	100
All Green	101	X	X	X	010	010
All Blue	101	X	X	X	001	001
Monochrome white Screen	111	X	X	X	8 bit value applied to all 3 monochrome white	

Figure 38 : Test Patterns

X: Don't care, LW: Line Width (0~255), CS: Column Space (0~255), RS: Row Space (0~255)

11.27 TPLINWTH (1Bh)

Name	TPLINWTH
Address	1Bh
Mode	Read / Write

Bit Name	Bit#	Reset Value	Description
	7-0	0	Test pattern line width

This register is used to set the line width for the line-type test patterns.

0 = 1 pixel wide (default)

1 = 2 pixel wide

...

255 = 256 pixel wide

11.28 TPCOLSP (1Ch)

Name	TPCOLSP
Address	1Ch
Mode	Read / Write

Bit Name	Bit#	Reset Value	Description
	7-0	0	Test pattern column spacing

This register is used to set the column spacing for the column-type test patterns.

0 = 1 pixel space (default)
1 = 2 pixel space
...
255 = 256 pixel space

11.29 TPROWSP (1Dh)

Name	TPROWSP
Address	1Dh
Mode	Read / Write

Bit Name	Bit#	Reset Value	Description
	7-0	0	Test pattern row spacing

This register is used to set the row spacing for the row-type test patterns.

0 = 1 pixel space (default)
1 = 2 pixel space
...
255 = 256 pixel space

11.30 TPMONochrome WHITE (1Eh)

Name	TPMONochrome WHITE
Address	1Eh
Mode	Read / Write

Bit Name	Bit#	Reset Value	Description
	7:0	7	Test pattern monochrome white or 256 gray level

This register is used to set the background and foreground monochrome whites (RGB) for certain test patterns.

When PATTSEL is selected to 4,5,or 6, bit2:0 is used as foreground monochrome white and bit6:4 as background monochrome white.
All 8 bits data is applied to RGB data for one of 256 grey level when PATTSEL is selected to 7.

11.31 DLYSEL (1Fh)

Name	DLYSEL
Address	1Fh
Mode	Read / Write

Bit Name	Bit#	Reset Value	Description
SKWDLY	7-4	0	LVDS skew align reference clock delay
CLKDLY	3-0	1	LVDS clock delay for serial data latch

SKWDLY :

0 = Base delay

1 = Base delay + 1 unit delay

...

15 = Base delay + 15 unit delay

CLKDLY :

0 = Base delay

1 = Base delay + 1 unit delay

...

15 = Base delay + 15 unit delay

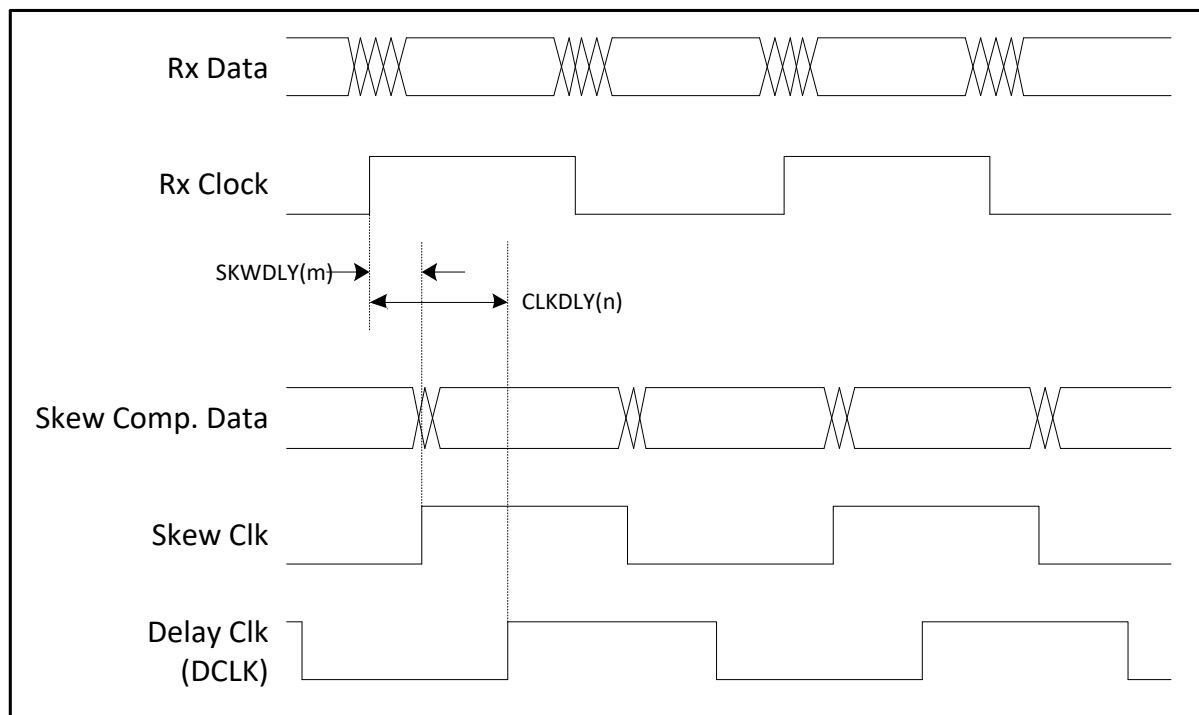

Figure 39 : LVDS Skew compensation timing diagram

11.32 LVDSCTL (20h)

Name	LVDSCTL
Address	20h
Mode	Read / Write

Bit Name	Bit#	Reset Value	Description
ALNMOD	2	0	Enable LVDS align mode
SKEWMOD	1-0	0	Select skew compensation mode

ALNMOD :

1 = Enable LVDS align mode

- LVDS Tx should send proper align pattern (10000000) on LVDS_DAT1 with ALIGN signal
- Don't set with SKEWMOD = 1 (auto skew compensation mode)

0 = Disable LVDS align mode (stay current align setting and any ALIGN and align pattern input are ignored)

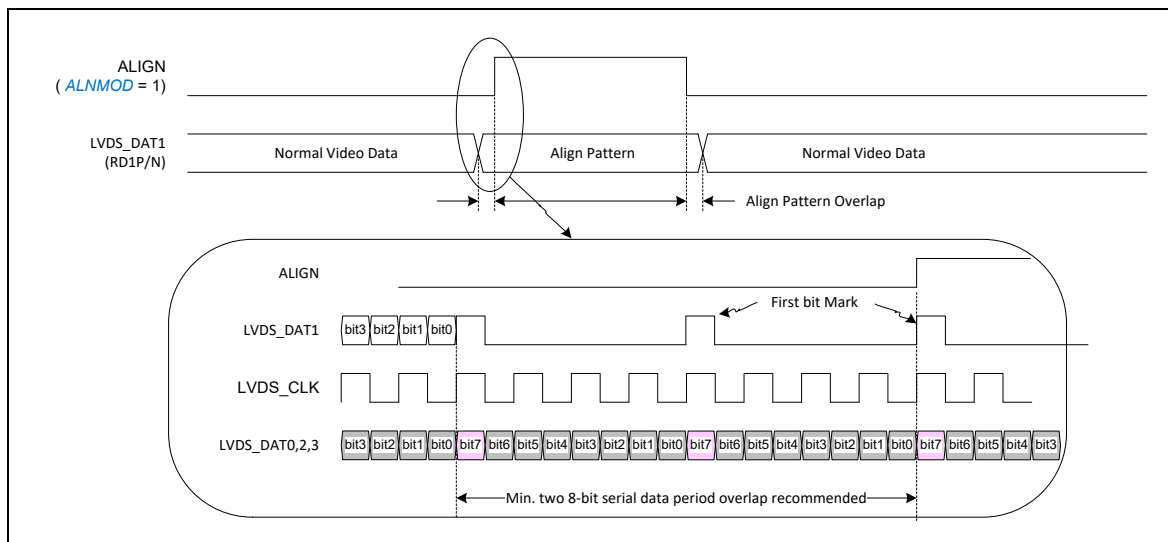

Figure 40 : LVDS Align pattern

ALNMOD should set after activate ALIGN signal and reset before deactivate ALIGN signal. It is recommended to use free running HSYNC as ALIGN signal.

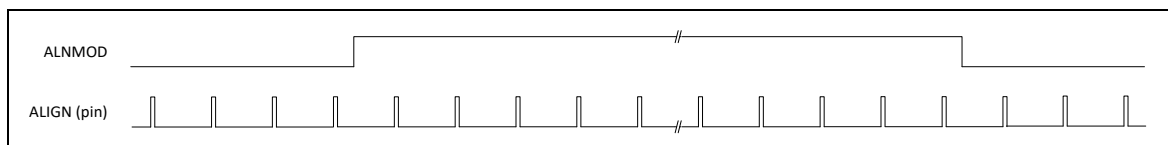

Figure 41 : ALIGN signal example

SKEWMOD:

- 0 = Normal operation mode (stays current skew delay setting and no change)
- 1 = Automatic skew delay setting mode
 - LVDS Tx should send proper Skew compensation pattern (00001111) on all data and clock
- 2 = Manual common skew delay setting mode (SKEW1 delay setting is used on all data line delay)
- 3 = Manual separate skew delay setting mode

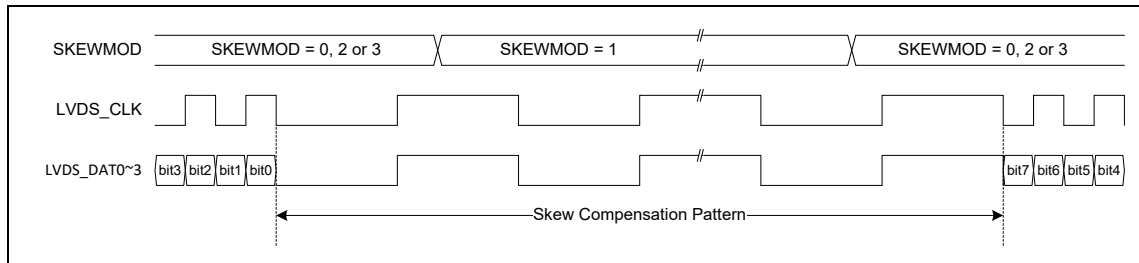

Figure 42 : Skew compensation pattern

The SKEWMOD register operation is only valid while LVDS TX is sending the skew compensation pattern.

11.33 SKEW0 (21h, 22h)

Name	SKEW0
Address	21h, 22h
Mode	Read / Write

Bit Name	Bit#	Reset Value	Description
SKEW0(21h)	7-0	0	data line #0 delay setting lower byte
SKEW0 (22h)	15-8	0	data line #0 delay setting upper byte

- 00000000 00000000 = Base delay setting
- 00000000 00000001 = Base + 1 unit delay setting
- 00000000 00000011 = Base + 2 unit delay setting
- 00000000 00000111 = Base + 3 unit delay setting
- 00000000 00001111 = Base + 4 unit delay setting
- ⋮
- 01111111 11111111 = Base + 14 unit delay setting
- 11111111 11111111 = Base + 15 unit delay setting

I²C register SKEW0~SKEW3 read out are always current working delay value

- SKEWMOD = 0 or 1 : current auto skew compensated values are read
- SKEWMOD = 2 : SKEW0 register value is applied to all other skew register and read on all SKEW0~SKEW3
- SKEWMOD = 3 : each SKEWi register values are applied and read

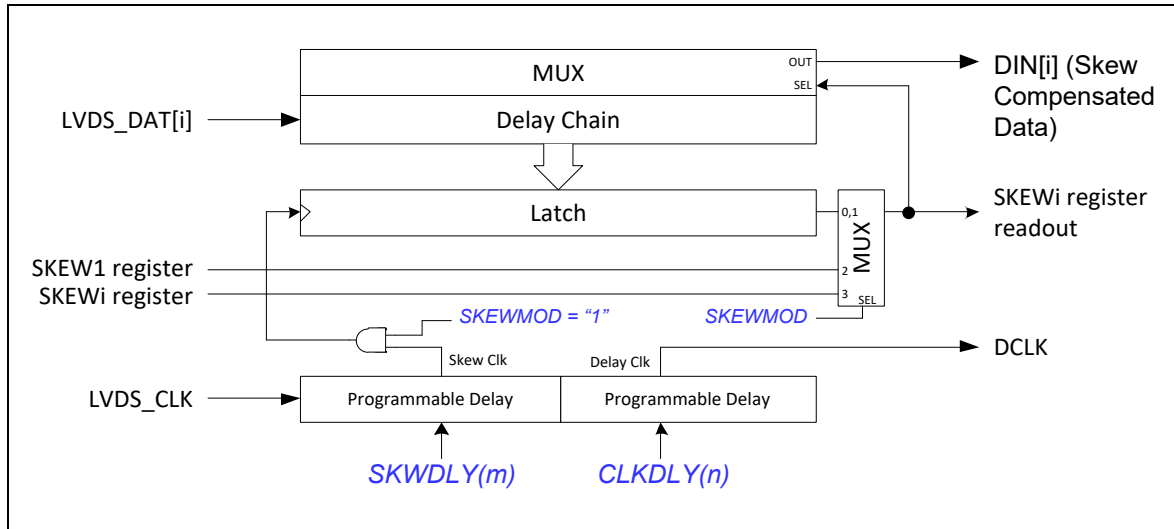

Figure 43 : Skew compensation block diagram

11.34 SKEW1 (23h, 24h)

Name	SKEW1
Address	23h, 24h
Mode	Read / Write

Bit Name	Bit#	Reset Value	Description
SKEW1 (24h)	7-0	0	data line #1 delay setting lower byte
SKEW1 (25h)	15-8	0	data line #1 delay setting upper byte

11.35 SKEW2 (25h, 26h)

Name	SKEW2
Address	25h, 26h
Mode	Read / Write

Bit Name	Bit#	Reset Value	Description
SKEW2 (25h)	7-0	0	data line #2 delay setting lower byte
SKEW2 (26h)	15-8	0	data line #2 delay setting upper byte

11.36 SKEW3 (27h, 28h)

Name	SKEW3
Address	27h, 28h
Mode	Read / Write

Bit Name	Bit#	Reset Value	Description
SKEW3 (27h)	7-0	0	data line #3 delay setting lower byte
SKEW3 (28h)	15-8	0	data line #3 delay setting upper byte

11.37 SKFAST (29h)

Name	SKFAST
Address	29h
Mode	Read Only

Bit Name	Bit#	Reset Value	Description
SKFAST	3-0	-	All "0" after skew compensation => OK

Bit 15 of SKEW0 ~ SKEW3. If any of SKFAST bit is read as "1" after skew compensation then that line comes much faster than selected skew clock. Decrease SKWDLY setting if possible.

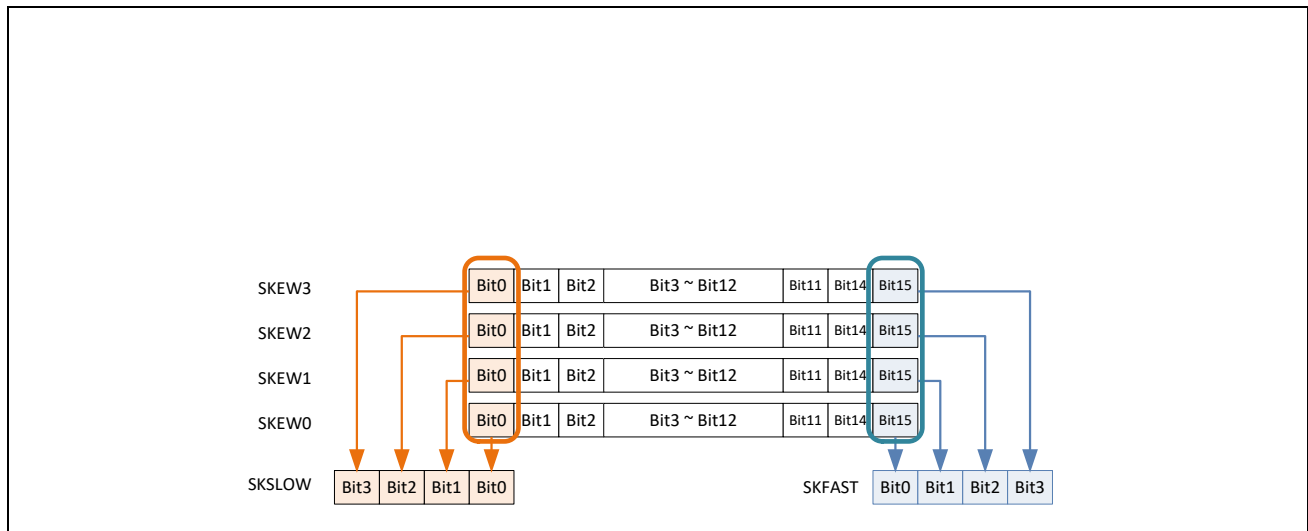

Figure 44 : SKFAST and SKSLOW register mapping

11.38 SKSLOW (2Ah)

Name	SKSLOW
Address	2Ah
Mode	Read Only

Bit Name	Bit#	Reset Value	Description
SKSLOW	3-0	0	All "1" after skew compensation => OK

Bit 0 of SKEW0 ~ SKEW3. If any of SKSLOW bit is read as "0" after skew compensation then that line comes to much slower than selected skew clock. Increase SKWDLY setting if possible.

11.39 SYNCMOD (2Bh)

Name	SYNCMOD
Address	2Bh
Mode	Read / Write

Bit Name	Bit#	Reset Value	Description
DEFEN	2-1	1	Define ENABLE pin function
DEFHS	0	0	Define LVDS_ALGN pin function

DEFEN:

- 0 = Do not use ENABLE pin (ENABLE & VSYNC signal uses thru LVDS data lines)
- 1 = ENABLE pin used as ENABLE (Default)
- 2 = ENABLE pin used as VSYNC
- 3 = Do not use

DEFHS:

- 0 = LVDS_ALGN pin used as ALIGN function
- 1 = LVDS_ALGN pin used as ALIGN & HSYNC function

11.40 LUT_ADDR (2Ch)

Name	LUT_ADDR
Address	2Ch
Mode	Read / Write

Bit Name	Bit#	Reset Value	Description
LUT_ADDR	7-0	0	Gamma look-up table template access address

11.41 LUT_DATA (2Dh, 2Eh)

Name	LUT_DATA
Address	2Dh, 2Eh
Mode	Read / Write

Bit Name	Bit#	Reset Value	Description
LUT_DATA_L (2Dh)	7-0	0	Gamma look-up table template R/W data LSB
LUT_DATA_H (2Eh)	9-8	0	Gamma look-up table template R/W data MSB

When LUT_DATA_L(2Dh) register is written following operations are happen

- Write Gamma look-up table template memory to LUT_DATA (10bit) data at current LUT_ADDR address
- Increase LUT_ADDR register by 1 after write operation

When LUT_DATA register are read following data are read

- Current LUT_ADDR address data of Gamma look-up table memory are read

11.42 LUT_UPDATE (2Fh)

Name	LUT_UPDATE
Address	2Fh
Mode	Read / Write

Bit Name	Bit#	Reset Value	Description
UDGAMMA	3	0	Update LUT template to R,G,B LUT memory
UDRGB	2-0	7	Select R,G,B Gamma LUT for Update

UDGAMMA:

0 = No operations happen

1 = Enable copy LUT template memory data to selected R,G,B Gamma LUT memory

UDGAMMA register operation

- R,G,B LUT memory update is started at first VSYNC rising edge meet after UDGAMMA register set to 1
- UDGAMMA register cleared to 0 after update operation end automatically

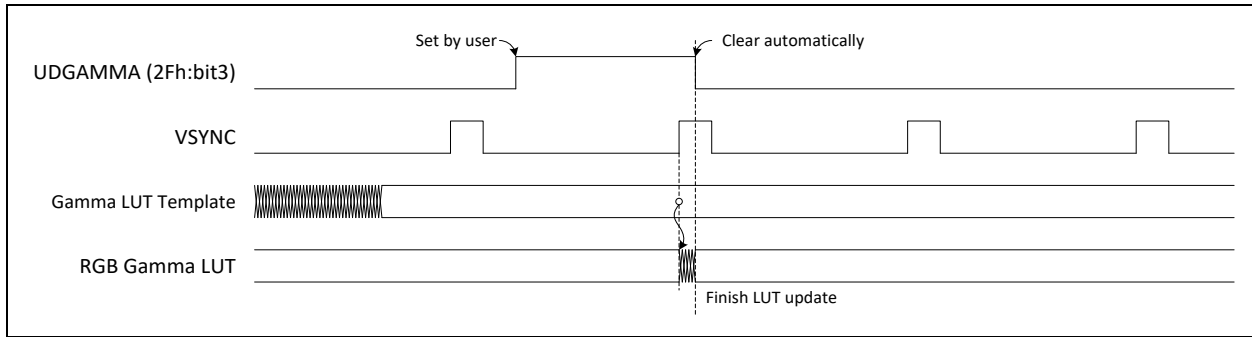

Figure 45 : Gamma LUT Update timing

UDRGB:

- 001 = Select B Gamma LUT memory updated
- 010 = Select G Gamma LUT memory updated
- 011 = Select G, B Gamma LUT memory updated
- 100 = Select R Gamma LUT memory updated
- 101 = Select R, B Gamma LUT memory updated
- 110 = Select R, G Gamma LUT memory updated
- 111 = Select R, G, B Gamma LUT memory updated

11.43 Reserved (30h, 31h, 32h, 33h)

Name	Reserved
Address	30h,31h,32h,33h
Mode	Read

Bit Name	Bit#	Reset Value	Description
	7-0	-	Reserved

11.44 Reserved (34h, 35h)

Name	Reserved
Address	34h,35h
Mode	Read / Write

Bit Name	Bit#	Reset Value	Description
	7-0	99	Reserved (Do Not Change)

11.45 Reserved (36h)

Name	Reserved
Address	36h
Mode	Read / Write

Bit Name	Bit#	Reset Value	Description
	3-0	0	Reserved (Do Not Change)

11.46 Reserved (37h)

Name	Reserved
Address	37h
Mode	Read / Write

Bit Name	Bit#	Reset Value	Description
	6-0	0	Reserved (Do Not Change)

11.47 Reserved (38h, 39h)

Name	Reserved
Address	38h,39h
Mode	Read / Write

Bit Name	Bit#	Reset Value	Description
	7-0	0	Reserved (Do Not Change)

11.48 Reserved (3Ah)

Name	Reserved
Address	3Ah
Mode	Read / Write

Bit Name	Bit#	Reset Value	Description
	7-0	FF	Reserved (Do Not Change)

11.49 Reserved (3Bh)

Name	Reserved
Address	3Bh
Mode	Read / Write

Bit Name	Bit#	Reset Value	Description
	7-0	0	Reserved (Do Not Change)

11.50 Reserved (3Ch)

Name	Reserved
Address	3Ch
Mode	Read / Write

Bit Name	Bit#	Reset Value	Description
	4-0	0	Reserved (Do Not Change)

11.51 Reserved (3Dh)

Name	Reserved
Address	3Dh
Mode	Read / Write

Bit Name	Bit#	Reset Value	Description
	2-0	3	Reserved (Do Not Change)

11.52 Reserved (40h)

Name	Reserved
Address	40h
Mode	Read / Write

Bit Name	Bit#	Reset Value	Description
	6-0	0	Reserved (Do Not Change)

11.53 Reserved (41h)

Name	Reserved
Address	41h
Mode	Read / Write

Bit Name	Bit#	Reset Value	Description
	7-0	30	Reserved (Do Not Change)

11.54 Reserved (42h)

Name	Reserved
Address	42h
Mode	Read / Write

Bit Name	Bit#	Reset Value	Description
	6-0	64	Reserved (Do Not Change)

13. APPENDIX B: LVDS TX DESIGN EXAMPLE

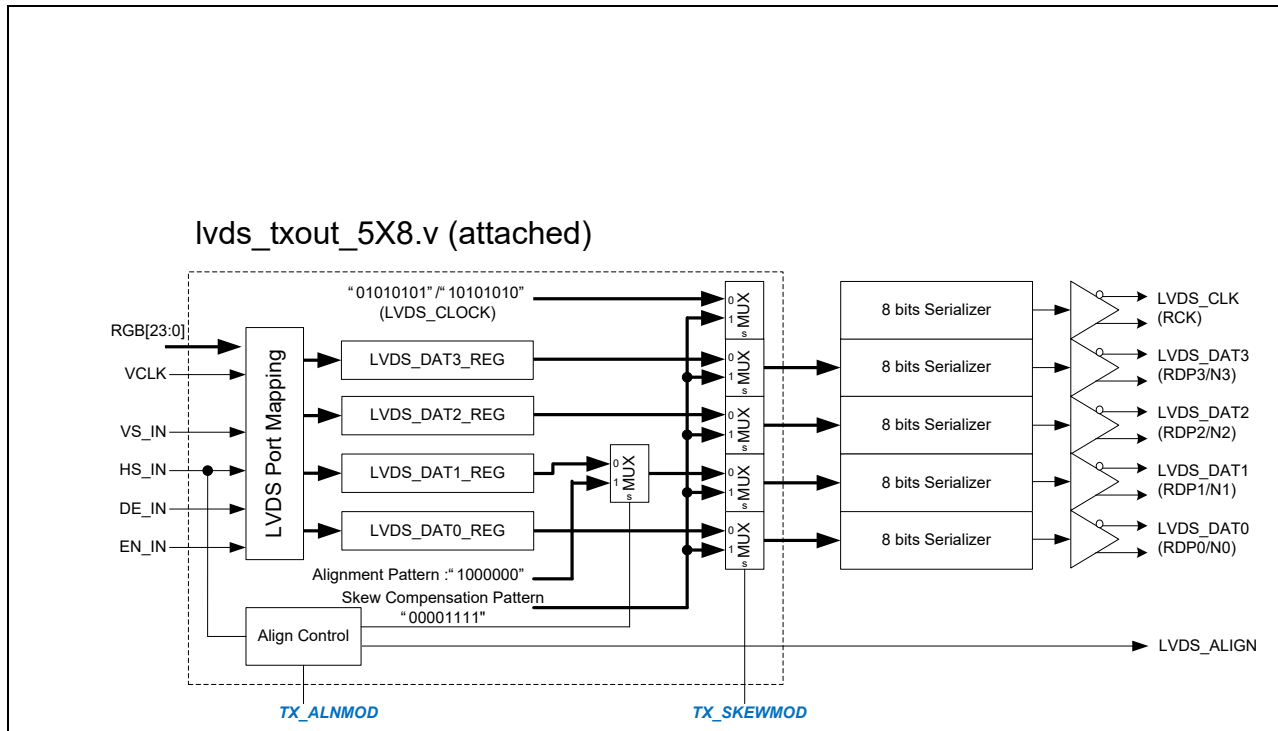

Figure 47 : LVDS TX Reference Design

The LVDS TX module should have two I2C registers, which are TX_ALNMOD and TX_SKEWMOD since LVDS RX requires special alignment and skew compensation patterns. ALNMOD Register: When it is set, the TX should send the alignment pattern via 2nd LVDS data channel (LVDS_DAT1) and LVDS_ALIGN signal which is a CMOS output. The alignment pattern is: “1000000”.

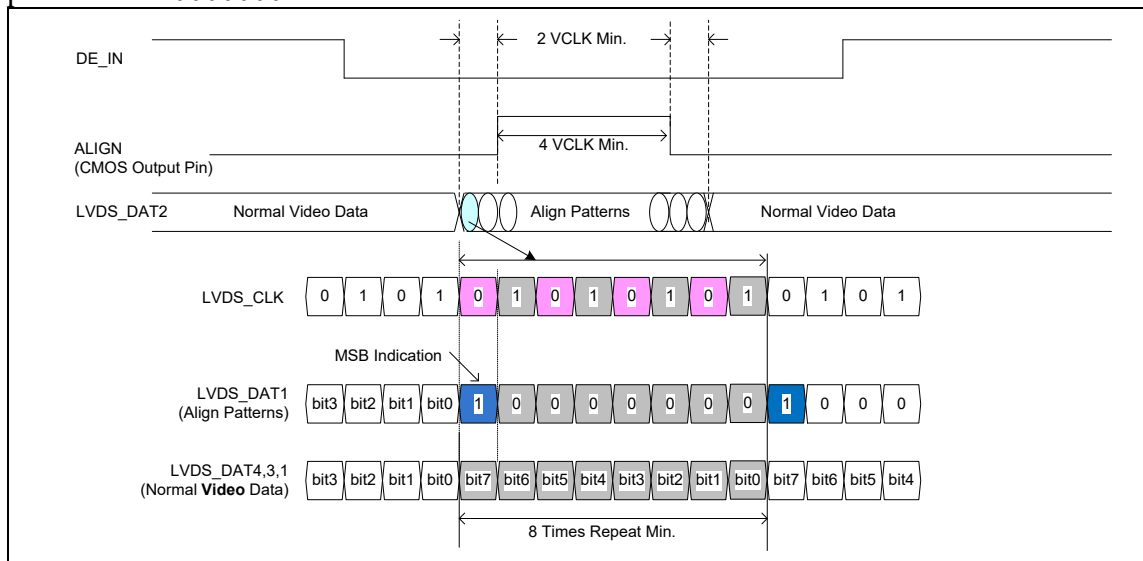

Figure 48 : LVDS Alignment Pattern and Timing

SKEWMOD Register: When it is set, the TX should send the skew compensation patterns through all of the LVDS channel including the clock channel. The skew compensation pattern is “0001111”.

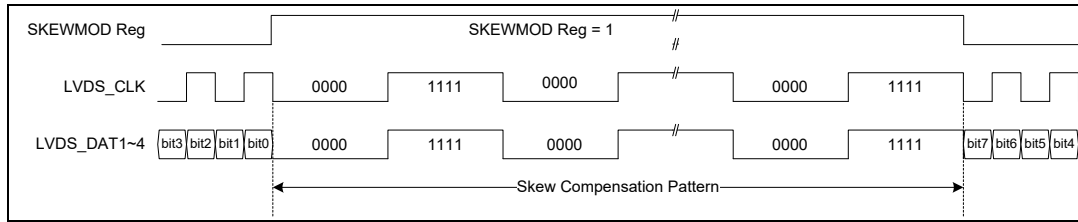

Figure 49 : LVDS Skew Compensation Pattern and Timing

Example RTL Code for LVDS TXOUT 5X8.v

```
// Created Tue Nov 26 11:31:11 2013
//-----
//
// Title       : LVDS_TXOUT_5X8
// Design      : SXGA096_FPGA
// Author      : Jae Koh
// Company     : eMagin
//-----
`timescale 1ns / 10ps

module LVDS_TXOUT_5X8 ( HS_IN ,HS_OUT ,rstn ,DIN ,EN_IN ,EN_OUT ,clk ,DOUT
,DE_IN ,VS_IN ,LVDSCTL ,LVDS_HS ,VS_OUT ,DE_OUT );

    input EN_IN ;
    wire EN_IN ;
    input HS_IN ;
    wire HS_IN ;
    input [23:0] DIN ;
    wire [23:0] DIN ;
    input clk ;
    wire clk ;
    input VS_IN ;
    wire VS_IN ;
    input DE_IN ;
    wire DE_IN ;
    input rstn ;
    wire rstn ;
    input [1:0] LVDSCTL ;          // {ALNMOD, SKWMOD}
    wire [1:0] LVDSCTL ;

    output EN_OUT ;
    wire EN_OUT ;
    output HS_OUT ;
    wire HS_OUT ;
    output VS_OUT ;
    wire VS_OUT ;
    output DE_OUT ;
    wire DE_OUT ;
    output [39:0] DOUT ;
    reg [39:0] DOUT ;
    output LVDS_HS ;
    reg LVDS_HS ;

    reg [87:0] DOUT0 ;
    reg [4:0] VSO, DEO, ENO;
    reg [7:0] HSO;
    wire ALGN;
    wire ALNMOD = LVDSCTL[1];
    wire SKWMOD = LVDSCTL[0];

    assign EN_OUT = ENO[4];
    assign VS_OUT = VSO[4];
    assign HS_OUT = HSO[4];
    assign DE_OUT = DEO[4];

    assign ALGN = ~DE_IN & (HS_IN | HSO[3] | HSO[7]) & ALNMOD;

    wire [7:0] RIN, GIN, BIN;

    assign RIN = DIN[23:16];
    assign GIN = DIN[15:8];
    assign BIN = DIN[7:0];

    always @(DOUT0)
        begin
            // LVDS_CLK
            DOUT[39] <= DOUT0[39];
            DOUT[38] <= DOUT0[38];
            DOUT[37] <= DOUT0[37];
            DOUT[36] <= DOUT0[36];
            DOUT[35] <= DOUT0[35];
            DOUT[34] <= DOUT0[34];
            DOUT[33] <= DOUT0[33];
            DOUT[32] <= DOUT0[32];
            // LVDS_D[3]
            DOUT[31] <= DOUT0[31];
            DOUT[30] <= DOUT0[30];
            DOUT[29] <= DOUT0[29];
            DOUT[28] <= DOUT0[28];
            DOUT[27] <= DOUT0[27];
            DOUT[26] <= DOUT0[26];
            DOUT[25] <= DOUT0[25];
            DOUT[24] <= DOUT0[24];
            // LVDS_D[2]
            DOUT[23] <= DOUT0[23];
            DOUT[22] <= DOUT0[22];
            DOUT[21] <= DOUT0[21];
            DOUT[20] <= DOUT0[20];
            DOUT[19] <= DOUT0[19];
        end
endmodule
```

```

DOUT[18] <= DOUT0[18];
DOUT[17] <= DOUT0[17];
DOUT[16] <= DOUT0[16];
// LVDS_D[1]
DOUT[15] <= DOUT0[15];
DOUT[14] <= DOUT0[14];
DOUT[13] <= DOUT0[13];
DOUT[12] <= DOUT0[12];
DOUT[11] <= DOUT0[11];
DOUT[10] <= DOUT0[10];
DOUT[9] <= DOUT0[9];
DOUT[8] <= DOUT0[8];
// LVDS_D[0]
DOUT[7] <= DOUT0[7];
DOUT[6] <= DOUT0[6];
DOUT[5] <= DOUT0[5];
DOUT[4] <= DOUT0[4];
DOUT[3] <= DOUT0[3];
DOUT[2] <= DOUT0[2];
DOUT[1] <= DOUT0[1];
DOUT[0] <= DOUT0[0];

end

always @(negedge rstn or negedge clk)
    if (!rstn)
        LVDS_HS <= 0;
    else
        LVDS_HS <= HSO[2];

always @(negedge rstn or posedge clk)
    if (!rstn)
        begin
            VSO <= 0;
            HSO <= 0;
            DEO <= 0;
            ENO <= 0;
            DOUT0 <= 0;
        end
    else
        begin
            VSO <= {VSO[3:0], VS_IN};
            HSO <= {HSO[6:0], HS_IN};
            DEO <= {DEO[3:0], DE_IN};
            ENO <= {ENO[3:0], EN_IN};

            if (SKWMOD)
                begin
                    DOUT0 <= 40'h0F0F0F0F0F;
                end
            else
                begin
                    DOUT0[39:32] <= 8'b01010101;
                    // RD3P/RD3N
                    DOUT0[31] <= BIN[5];
                    DOUT0[30] <= BIN[4];
                    DOUT0[29] <= BIN[3];
                    DOUT0[28] <= BIN[1];
                    DOUT0[27] <= BIN[0];
                    DOUT0[26] <= BIN[2];
                    DOUT0[25] <= BIN[6];
                    DOUT0[24] <= ~BIN[6];
                    // RD2P/RD2N
                    DOUT0[23] <= RIN[0];
                    DOUT0[22] <= DE_IN;
                    DOUT0[21] <= HS_IN;
                    DOUT0[20] <= EN_IN;
                    DOUT0[19] <= VS_IN;
                    DOUT0[18] <= BIN[7];
                    DOUT0[17] <= GIN[7];
                    DOUT0[16] <= ~GIN[7];
                    // RD1P/RD1N
                    if (ALGN)
                        begin
                            DOUT0[15] <= 1;
                            DOUT0[14] <= 0;
                            DOUT0[13] <= 0;
                            DOUT0[12] <= 0;
                            DOUT0[11] <= 0;
                            DOUT0[10] <= 0;
                            DOUT0[9] <= 0;
                            DOUT0[8] <= 0;
                        end
                    else
                        begin
                            DOUT0[15] <= GIN[6];
                            DOUT0[14] <= GIN[5];
                            DOUT0[13] <= GIN[1];
                            DOUT0[12] <= GIN[0];
                            DOUT0[11] <= GIN[4];
                            DOUT0[10] <= GIN[3];
                            DOUT0[9] <= GIN[2];
                            DOUT0[8] <= ~GIN[2];
                        end
                end
            // RD0P/RD0N
        end
    end

```

```
                                DOUT0[7] <= RIN[7];
                                DOUT0[6] <= RIN[1];
                                DOUT0[5] <= RIN[6];
                                DOUT0[4] <= RIN[5];
                                DOUT0[3] <= RIN[4];
                                DOUT0[2] <= RIN[3];
                                DOUT0[1] <= RIN[2];
                                DOUT0[0] <= ~RIN[2];
                                end
                                end
endmodule
```

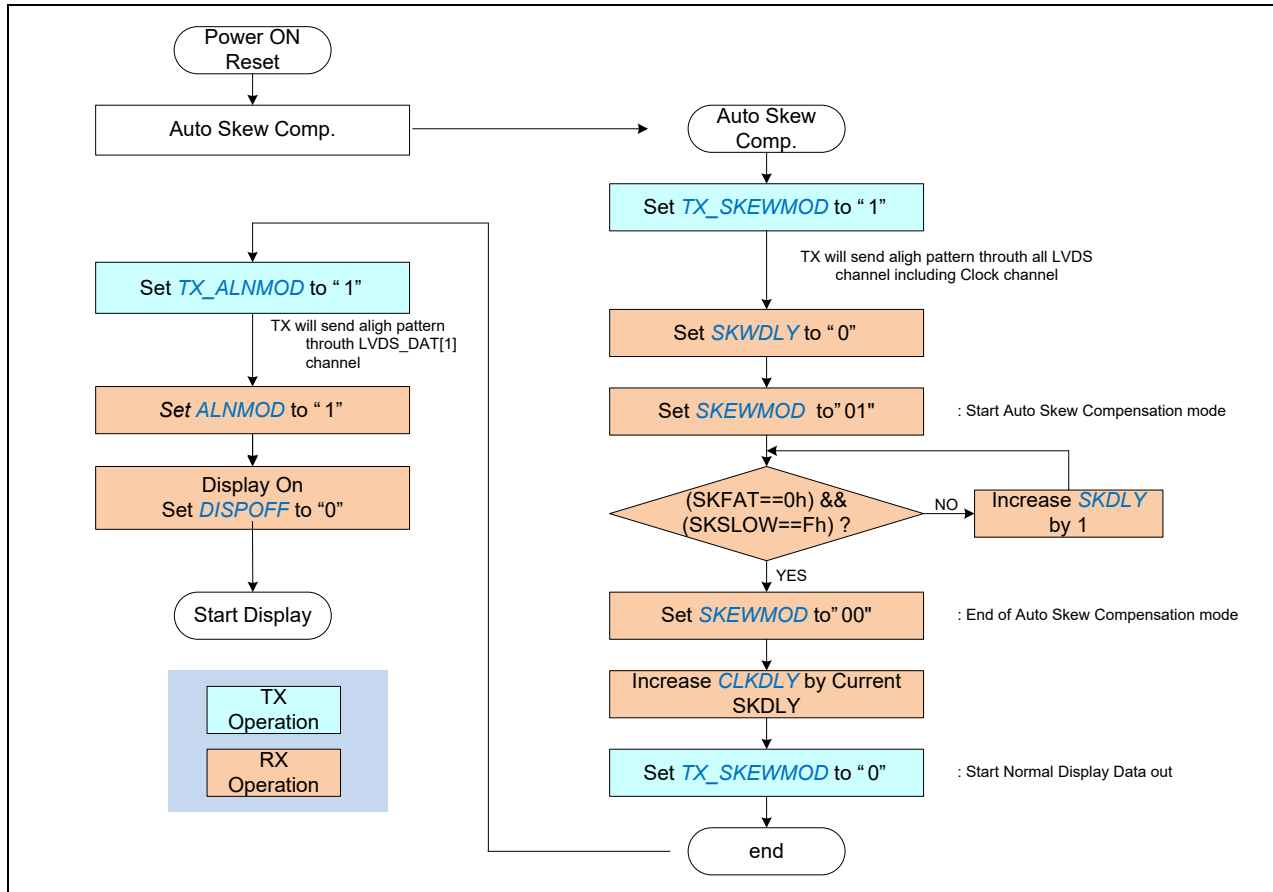

Figure 50 : LVDS Link Setup Flow Chart for Firmware

14. APPENDIX C: EEPROM MEMORY MAP

Each SXGA096 micro display contains an EEPROM memory device to serve as non-volatile data storage for retrieving display specific information, such as its serial number and optimal registers values for proper operation. The data can be accessed via the same I²C serial interface that is used to communicate with the micro display. The EEPROM'S serial address is as follows:

SERADD = 0

Write Mode: Address is A6h

Read Mode: Address is A7h

SERADD = 1

Write Mode: Address is AEh

Read Mode: Address is AFh

The first 15 bytes represent the serial number of the SXGA096 micro display. The following 68 bytes contain sequential data values that can be used to write to the micro display's internal registers starting with eeprom address 16 to 84.

Addresses 00 to 15 (decimal) should not be changed as they contain serial number and traceability information

Addresses 34, 36, 37, 142-145 contain calibrated values specific to each display and should not be changed

Address 34 contains the IDRF value needed to reach 5,000 cd/m² at room ambient

Addresses 36 and 37 contain the on-chip temperature sensor calibration values, needed to correctly measure the display temperature

Addresses 142-145 contain the information needed to calculate the IDRF needed set an absolute luminance (in cd/m²).

Registers defined as RESERVED should not be changed.

Addresses beyond 91h are blank and may be used.

NOTE: The EEPROM is not write-protected and care should be taken not to activate the Write Mode. The values highlighted in gray are measured at the factory and are specific to each individual device.

Memory Addr (Dec)	Memory Addr (hex)	EEPROM Data	Memory Addr (Dec)	Memory Addr (hex)	EEPROM Data
0	0	Serial Char #0	43	2B	TPLINWTH
1	1	Serial Char #1	44	2C	TPCOLSP
2	2	Serial Char #2	45	2D	TPROWSP
3	3	Serial Char #3	46	2E	TPCOLOR
4	4	Serial Char #4	47	2F	DLYSEL
5	5	Lot Char#0	48	30	LVDSCTL
6	6	Lot Char#1	49	31	SKEW0L
7	7	Lot Char#2	50	32	SKEW0H
8	8	Lot Char#3	51	33	SKEW1L
9	9	Lot Char#4	52	34	SKEW1H
10	A	Lot Char#5	53	35	SKEW2L
11	B	Wafer Char#0	54	36	SKEW2H
12	C	Wafer Char#1	55	37	SKEW3L
13	D	Wafer Char#2	56	38	SKEW3H
14	E	Wafer Char#3	57	39	SKFAST
15	F	Data Format Version# (00h)	58	3A	SKSLOW
16	10	STAT	59	3B	SYNCMOD
17	11	VINMODE	60	3C	LUT_ADDR
18	12	DISPMODE	61	3D	LUT_DATA_L
19	13	LFTPOS	62	3E	LUT_DATA_H
20	14	RGTPOS	63	3F	LUT_UPDATE
21	15	TOPPOS	64	40	NOFPIXELL
22	16	BOTPOS	65	41	NOFPIXELH
23	17	ROWRESETL	66	42	NOFLINEL
24	18	ROWRESETH	67	43	NOFLINEH
25	19	RAMPCTL	68	44	NVCK0
26	1A	RAMPCM	69	45	NVCK1
27	1B	VDACMX	70	46	PUPCTL
28	1C	BIASN	71	47	HIDNCTL
29	1D	GAMMASET	72	48	DIGTEST
30	1E	VCOMMODE	73	49	Reserved
31	1F	VCOMCTL	74	4A	Reserved
32	20	VGMAX	75	4B	Reserved
33	21	VCOM	76	4C	Reserved
34	22	IDRF	77	4D	Reserved
35	23	DIMCTL	78	4E	Reserved
36	24	TREFDIV	79	4F	DISPMOD_BN
37	25	TEMPOFF	80	50	IDRF_BN
38	26	TUPDATE	81	51	DIMCTL_BN
39	27	TEMPOUT	82	52	Reserved
40	28	ANGPWRDN	83	53	Reserved
41	29	SYSPWRDN	84	54	Reserved
42	2A	TPMODE	85	55	VGNA0_HI

Memory Addr (Dec)	Memory Addr (hex)	EEPROM Data	Memory Addr (Dec)	Memory Addr (hex)	EEPROM Data
86	56	VGNA0_LO	129	81	GMMA06_HI
87	57	VGNA1_HI	130	82	GMMA06_LO
88	58	VGNA1_LO	131	83	GMMA07_HI
89	59	VGNA2_HI	132	84	GMMA07_LO
90	5A	VGNA2_LO	133	85	Blank
91	5B	VGNA3_HI	134	86	Blank
92	5C	VGNA3_LO	135	87	Blank
93	5D	VGNA4_HI	136	88	Blank
94	5E	VGNA4_LO	137	89	MM
95	5F	VGNA5_HI	138	8A	DD
96	60	VGNA5_LO	139	8B	YY
97	61	VGNA6_HI	140	8C	YY
98	62	VGNA6_LO	141	8D	Blank
99	63	VGNA7_HI	142	8E	slope1 (int)
100	64	VGNA7_LO	143	8F	slope2 (frac)
101	65	VGNB0_HI	144	90	Origin_L
102	66	VGNB0_LO	145	91	Origin_H
103	67	VGNB1_HI			
104	68	VGNB1_LO			
105	69	VGNB2_HI			
106	6A	VGNB2_LO			
107	6B	VGNB3_HI			
108	6C	VGNB3_LO			
109	6D	VGNB4_HI			
110	6E	VGNB4_LO			
111	6F	VGNB5_HI			
112	70	VGNB5_LO			
113	71	VGNB6_HI			
114	72	VGNB6_LO			
115	73	VGNB7_HI			
116	74	VGNB7_LO			
117	75	GMMA00_HI			
118	76	GMMA00_LO			
119	77	GMMA01_HI			
120	78	GMMA01_LO			
121	79	GMMA02_HI			
122	7A	GMMA02_LO			
123	7B	GMMA03_HI			
124	7C	GMMA03_LO			
125	7D	GMMA04_HI			
126	7E	GMMA04_LO			
127	7F	GMMA05_HI			
128	80	GMMA05_LO			

15. APPENDIX D: RECOMMENDED REGISTER SETTINGS

00h: STATUS	00	15h: TMPOFF	54	2Ah: SKSLW	0F	3Fh: RES	00
01h: VINMODE	07	16h: TUPDTE	10	2Bh: SYNCMD	02	40h: RES	00
02h: DISPMODE	60	17h: TEMPOUT	AA	2Ch: LUT_ADR	FF	41h: RES	30
03h: LFTPOS	06	18h: ANGPRDN	00	2Dh: LUTDL	F2	42h: RES	64
04h: RGTPOS	06	19h: SYSPRDN	20	2Eh: LUTDH	03		
05h: TOPPOS	06	1Ah: TPMODE	00	2Fh: LUT_UP	07		
06h: BOTPOS	06	1Bh: TPLNWTH	00	30h: RES	00		
07h: ROWRSTL	00	1Ch: TPCOLSP	00	31h: RES	05		
08h: ROWRSTH	00	1Dh: TPROWSP	00	32h: RES	00		
09h: RAMPCTL	01	1Eh: TPCOLOR	00	33h: RES	04		
0Ah: RAMPCM	44	1Fh: DLYSEL	AA	34h: RES	99		
0Bh: VDACMX	80	20h: LVDSCTL	04	35h: RES	99		
0Ch: BIASN	03	21h: SKEW0L	3F	36h: RES	00		
0Dh: GAMMST	00	22h: SKEW0H	00	37h: RES	00		
0Eh: VCOMMDE	04	23h: SKEW1L	3F	38h: RES	00		
0Fh: VCOMCTL	3D	24h: SKEW1H	00	39h: RES	00		
10h: VGMAX	4D	25h: SKEW2L	3F	3Ah: RES	FF		
11h: VCOM	51	26h: SKEW2H	00	3Bh: RES	00		
12h: IDRFB	40	27h: SKEW3L	3F	3Ch: RES	00		
13h: DIMCTL	64	28h: SKEW3H	00	3Dh: RES	03		
14h: TREFDV	17	29h: SKFST	00	3Eh: RES	00		