



# SVGA+ OLED-XL<sup>(TM)</sup> Microdisplay

## SVGA+ OLED-XL MICRODISPLAY CAPABILITIES

eMagin introduces the SVGA+ OLED-XL and Rev 3 series, the most power efficient OLED microdisplay solution for near-eye devices.

Proven in military and first-responder systems, the original SVGA+ OLED microdisplay delivers high-resolution, flicker-free images for near-eye applications – even under adverse conditions.

The new SVGA+ OLED-XL shares all the functional and rugged design characteristics of the original microdisplay. It responds instantly, even at -40°C. Its built-in video control electronics eliminate the need for additional circuit boards.

SVGA+ Rev 3 is even lower-power operation from permanently disabling the internal Vbh and Vbl references, thereby reducing internal power requirements by an average 80mW over previous SVGA+ products. In addition, this switch to requiring external references creates a microdisplay that has simpler calibration over temperature and is ideal for demanding binocular luminance and color matching.

Under typical usage conditions (60 Hz video at 70 cd/m<sup>2</sup>) the full color SVGA+ OLED-XL requires less than 165mW, while the monochrome white version uses only 115mW (in RS170 mode). And no heaters or special operating modes are required to achieve high quality, instant-on video performance at temperatures up to -40°C and +65°C.

The SVGA+ OLED-XL extends the tradition and leadership of eMagin's SVGA+ OLED microdisplay with even greater efficiency and higher brightness.

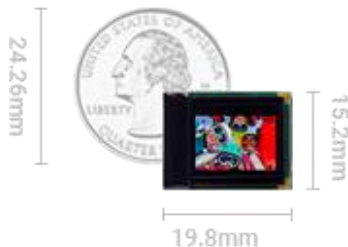

## SVGA+ OLED-XL MICRODISPLAY ADVANTAGES

- Very low power requirements
- No heaters required
- No clearing at high temperature
- Extended luminance lifetime
- Easy integration into designs based on original OLED microdisplays
- Available in full-color, monochrome white and monochrome green

## APPLICATIONS

- Night vision/thermal imaging
- Situational awareness
- Command and control
- Field maintenance and repair
- Instrumentation and test equipment
- Mobile computing systems
- Augmented reality
- Personal entertainment systems

### eMagin Corporation

700 South Drive Suite #201  
Hopewell Junction, NY 12533  
tel. 845.838.7900  
fax 845.838.7901  
[sales@emagin.com](mailto:sales@emagin.com)  
[www.emagin.com](http://www.emagin.com)

## GENERAL OPERATING CHARACTERISTICS

### FORMAT

- 852 (x 3) x 600

### PIXEL PITCH & ASPECT RATIO

- 15  $\mu$ m square

### COLOR PIXEL ARRANGEMENT

- R,G,B vertical stripe

### VIEWING AREA

- 12.78 x 9 mm (0.61" diagonal)

### DISPLAY ASPECT RATIO

- 4:3 or 16:9

### MECHANICAL ENVELOPE

- 19.78 x 15.2 x 5 mm (w x l x h)

### COLOR GAMUT

- >75% of NTSC gamut
- Up to 256 gray levels

### UNIFORMITY

- >85% (area uniformity as per VESA FPDM Standard)

### CONTRAST RATIO

- >800:1 (White, Green); >200:1 (Color)

#### LUMINANCE MAXIMUM

- Color XL 400 cd/m<sup>2</sup>
- Monochrome White 2,000 cd/m<sup>2</sup>
- Monochrome Green 20,000 cd/m<sup>2</sup>

#### TEMPERATURE

- Operating: -46°C to >+70°C
- Storage: -55°C to +90°C

#### HUMIDITY

- 85% RH non-condensing

### VIDEO INPUTS

#### R, G, B INPUTS

- 0 to 0.7V, compatible with VESA VSIS standard
- SMPTE-170 & PAL (monochrome only)

#### VIDEO FORMATS

- SVGA (or any window up to full array)
- Stereovision compatible

#### VIDEO SIGNAL BANDWIDTH

- 56 MHz maximum (VESA SVGA 85 Hz mode)

#### CONTROL & SERIAL INTERFACE

- Digital 3.3V CMOS

#### FRAME RATE

- 30Hz to 85 Hz

### POWER INTERFACE

#### LOGIC/ & ANALOG SUPPLY (VDD)

- 3.3V dc @ 50 mA Max.

#### TOTAL POWER DISSIPATION

- <175 mW typical (full color display)
- <115 mW typical (monochrome display) RS 170

#### OLED SUPPLY

- 4.0V dc (4.6V maximum) @ 50 mA Max.

#### CLOCK RECOVERY

- PLL

\* Data represent performance at 20°C for standard commercial and industrial pricing.

Characteristics will vary with temperature requirements. Low-cost commercial or consumer operating specifications may vary.

## BLOCK DIAGRAM

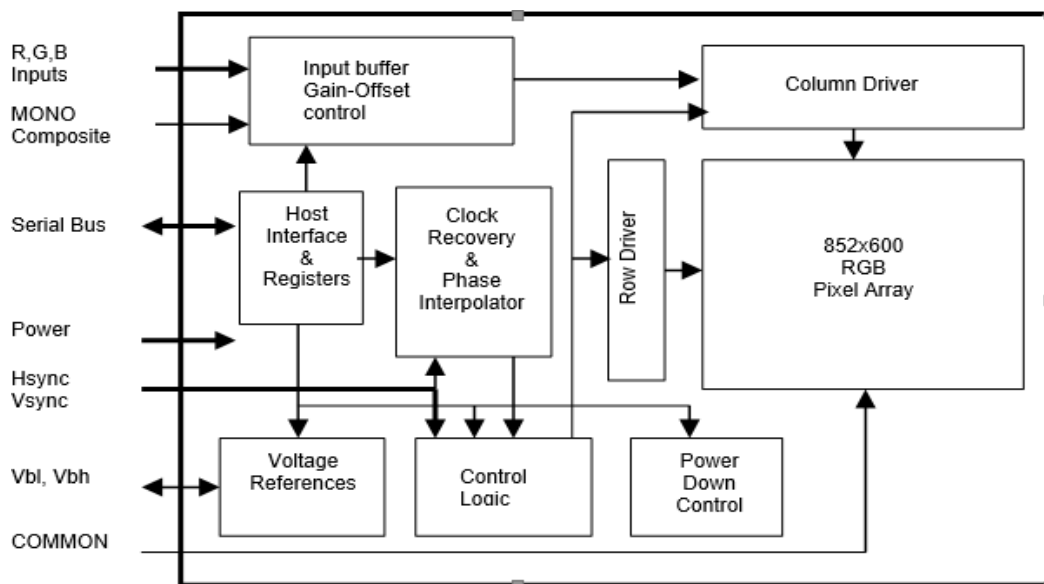

eMagin Corporation is a registered trademark of eMagin Corporation. All other products mentioned herein are trademarks of their respective owners and are hereby recognized as such. eMagin Corporation reserves the right to change products and specifications without prior notice. This information does not convey any license by any implication or otherwise under any patents or other rights. Application circuits shown, if any, are typical examples illustrating the operation of the devices. This information is subject to change without notice. ©2023, eMagin Corporation, Hopewell Junction, NY. All rights reserved.