



## VGA OLED-XL™ Microdisplays

### VGA OLED-XL MICRODISPLAY CAPABILITIES

Designed specifically for near-to-eye applications demanding high image quality, compact size, and very low power, the VGA OLED-XL active matrix microdisplay delivers crisp, high-contrast imagery via eMagin's True Black™ pixel technology. The voltage drive design provides dramatic improvement in pixel uniformity (in a 0.50 inch diagonal active area) requiring less than 60mW under typical monochrome operation (<150mW full color).

The new VGA microdisplays provide versatility and flexibility for OEM developers through an FPGA driver design available on a separate, lower power driver board, or as source code for integration into end product electronics for maximum power efficiency. Pulse-width modulation on pixel hold times substantially eliminates motion artifacts in video images, and also improves the dimming range and gray level response for low light and night vision applications. Additional enhancements include, digital interface, wider color gamut, on-chip temperature sensor and automatic compensation for luminance and gamma correction for consistent color and brightness over a wide range of operating temperatures.

The total pixel array of 680 x 520 can be used for electronic alignment of a 640 x 480 (VGA) window with the ability to move the image up to 20 pixels horizontally and/or vertically, or the entire array can be addressed pixel by pixel. Display feature and timing options are selected by means of registers that are programmed through the serial port or controlled through the FPGA.

Proven in military, commercial, and consumer systems, eMagin's portfolio of OLED microdisplays deliver high-resolution, flicker-free virtual images, even in extreme temperatures and high-vibration conditions that challenge legacy technologies.



### VGA OLED-XL MICRODISPLAY ADVANTAGES

- Compact, lightweight, emissive display system
- High-contrast with very low power requirement
- Improved pixel uniformity
- Instant on at low temperatures; no heaters required
- Integrated temperature sensor
- No clearing at high temperature
- High commercial/military ruggedness
- No back light or liquid materials required

### APPLICATIONS

- Situational awareness
- Personal display systems
- Night vision/thermal imaging
- Command and control
- Field maintenance and repair
- Instrumentation and test equipment
- Mobile computing systems
- Augmented reality



### eMagin Corporation

700 South Drive Suite #201  
Hopewell Junction, NY 12533  
tel 845.838.7900  
fax 845.838.7901  
[sales@emagin.com](mailto:sales@emagin.com)  
[www.emagin.com](http://www.emagin.com)

## GENERAL OPERATING CHARACTERISTIC

### FORMAT

- 640 (x 3) x 480
- Total pixel array 680 (x3) x 520

### PIXEL PITCH & ASPECT RATIO

- 15  $\mu\text{m}$  square

### COLOR PIXEL ARRANGEMENT

- R,G,B vertical stripe

### VIEWING AREA

- 10.02 X 7.80 mm (0.50 inch diagonal)
- Electronic image centering (1 to 20 pixels H and V)

### DISPLAY ASPECT RATIO

- 4:3

### MECHANICAL ENVELOPE

- 16.5 x 18 x 5.01 mm (w/Hirose 50- pin DF 12 connector)

### COLOR GAMUT

- >75% of NTSC gamut
- Up to 256 gray levels

### UNIFORMITY

- >90% End to end
- >95% Pixel to pixel uniformity

### CONTRAST RATIO

- >10,000:1
- Dimming ratio (combinable multiplier)
  - Analog mode >500:1
  - PWM mode >200:1

### LUMINANCE MAXIMUM

- Color 400 cd/m<sup>2</sup>
- Monochrome White 1,800 cd/m<sup>2</sup>
- Monochrome Green 3,000 cd/m<sup>2</sup>

### TEMPERATURE

- Operating: -46°C to >+70°C
- Storage: -55°C to +90°C

### HUMIDITY

- 85% RH non-condensing

## VIDEO INPUTS

### R, G, B INPUTS

- RGB 30-bit digital

### VIDEO FORMATS

- VGA
- Frame or Field sequential stereovision

### VIDEO SIGNAL BANDWIDTH

- 50 MHz maximum

### CONTROL & SERIAL INTERFACE

- I<sup>2</sup>C Serial Interface

### FRAME RATE

- up to 120 Hz

## POWER INTERFACE

### POWER SUPPLY (V<sub>DD</sub>)

- 2.5 Vdc (logic), 5Vdc analog/display

### TOTAL POWER DISSIPATION

- <150 mW typical (full color display)
- <60 mW typical (monochrome display)

\* Data represent performance at 20°C for standard commercial and industrial pricing. Characteristics will vary with temperature requirements. Low-cost commercial or consumer operating specifications may vary.

## BLOCK DIAGRAM

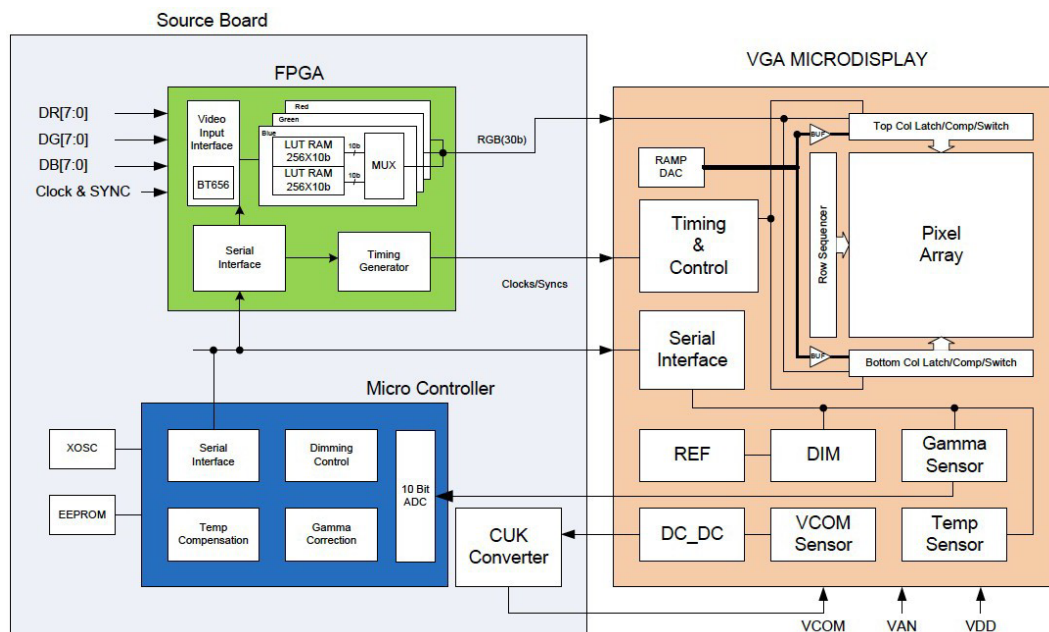

eMagin Corporation is a registered trademark of eMagin Corporation. All other products mentioned herein are trademarks of their respective owners and are hereby recognized as such. eMagin Corporation reserves the right to change products and specifications without prior notice. This information does not convey any license by any implication or otherwise under any patents or other rights. Application circuits shown, if any, are typical examples illustrating the operation of the devices. This information is subject to change without notice. ©2023 eMagin Corporation, Hopewell Junction, NY. All rights reserved.